TUNGSTEN SMART-HEAT™ PORTABLE HEATER BY BROMIC

INSTALLATION, INSTRUCTION AND SERVICE MANUAL

SUITABLE FOR GAS RADIANT HEATER MODELS:
TUNGSTEN SMART-HEAT™ PORTABLE

 WARNING

Do not store or use petrol or other flammable vapor and liquids in the vicinity of this or any other appliance.

An LP-cylinder not connected for use shall not be stored in the vicinity of this or any other appliance.



WARNING: Improper installation, adjustment, alteration, service or maintenance can cause property damage, injury or death. Read the installation, operating and maintenance instructions thoroughly before installing or servicing this equipment.



DANGER

If you smell gas:

1. Shut off gas to the appliance
2. Extinguish any open flame
3. If odour continues, keep away from the appliance and immediately call your gas supplier or fire department.



WARNING: For Outdoor Use Only. This appliance shall not be installed or used indoors.





This manual contains important information about the assembly, operation, and maintenance of TUNGSTEN Smart-Heat™ Heaters. Please pay close attention to the important safety information shown throughout this instruction manual. Any safety information will be accompanied by the following safety alert symbols:

 DANGER  WARNING,  IMPORTANT

READ THIS MANUAL CAREFULLY before installing or servicing this product

- Service and repair must only be done by a qualified service person.
- The heater should be inspected before use and at least annually by a qualified service person.
- Improper installation, operation, or maintenance can result in death, severe injury, or property damage.
- This manual must be kept following installation for future reference.

BROMIC[®]
HEATING

Head Office: 10 Phiney Place, Ingleburn NSW 2565 Australia
Telephone: 1300 276 642 (within Australia) or +61 2 9748 3900 (from overseas)

Note: Bromic Heating Pty Ltd reserves the right to make changes to specifications, parts, components and equipment without prior notification. This Installation, operation and service manual may not be reproduced in any form without prior written consent from Bromic Heating Pty Ltd.

CONTENTS

IMPORTANT NOTES & WARNINGS	4
PRODUCT OVERVIEW	5
PRODUCT DESCRIPTION	5
SPECIFICATIONS	5
GENERAL INFORMATION	6
PRODUCT FEATURES	6
INSTALLATION REQUIREMENTS	7-8
GAS REQUIREMENTS	7
INSTALLATION CLEARANCES	8
INSTALLATION INSTRUCTIONS	9-20
HEATER INSTALLATION INSTRUCTIONS	9-19
LEAKAGE TEST	20
OPERATING INSTRUCTIONS	21
TURNING THE APPLIANCE ON	21
TURNING THE APPLIANCE OFF	21
MAINTENANCE AND SERVICING	22
REPLACEMENT PARTS	23
TROUBLE SHOOTING	24
APPENDIX A	25 - 27
WARRANTY	28

DO NOT INSTALL OR USE THIS APPLIANCE INDOORS

DO NOT USE OR STORE FLAMMABLE MATERIALS IN THE APPLIANCE STORAGE
DRAWER OR NEAR THIS APPLIANCE!

'DO NOT MODIFY THIS APPLIANCE'.

'DO NOT USE THIS APPLIANCE AS A SPACE HEATER'.

CHILDREN AND ADULTS SHOULD BE ALERTED TO THE HAZARDS OF HIGH SURFACE
TEMPERATURES AND SHOULD STAY AWAY TO AVOID BURNS OR CLOTHING IGNITION.

CHILDREN SHOULD BE CAREFULLY SUPERVISED WHEN THEY ARE IN THE AREA OF THE HEATER.

CLOTHING OR OTHER FLAMMABLE MATERIALS SHOULD NOT BE HUNG FROM THE HEATER OR PLACED
ON OR NEAR THE HEATER

IMPORTANT NOTES AND WARNINGS



WARNING

Failure to follow the warnings and instructions in this manual could result in severe personal injury, death or property damage.

- This appliance must be used only in an outdoor area and shall not be used in a building, garage or any other enclosed area. This appliance must not be installed or used indoors.
 - Do not place articles on or against this appliance.
 - Any guard or other protective device removed for servicing (conducted by an authorised person) must be replaced before operating the heater.
 - The base of the appliance must be filled with sand as shown later in these instructions. Do not operate this appliance unless the base is filled with sand.
 - The hose assembly is not to be located in areas where the hose may be subject to accidental damage.
 - Remove transit protection before use.
 - Turn off the gas cylinder valve immediately if smell of gas is detected.
 - Do not transport or move the heater while it is operating.
 - The heater should be inspected before use and at least annually by a qualified service person.
 - Do not use or store flammable materials near this appliance
 - Do not spray aerosols or flammable materials in the vicinity of this appliance while it is in operation
 - Any guard or other protective device removed for servicing (conducted by an authorised person) must be replaced before operating the heater.
 - Children and adults should be alerted to the hazards of high surface temperatures and should stay away to avoid burns or clothing ignition.
 - Children should be carefully supervised when they are in the area of the heater.
 - Clothing or other flammable materials should not be hung from the heater or placed on or near the heater.
 - Do not perform maintenance until heater has been turned off, and heater temperature has cooled to room temperature.
 - Do not expose the burner to water or moisture. The appliance must be protected from rain.
 - Do not use the heater if any of these parts are exposed to water until the appliance is inspected or repaired by an authorised service person.
 - The installer is to ensure that the requirements of the local authority, local gas fitting regulations, municipal building codes, and any other relevant statutory regulations are carried out.
 - Certain materials or items, when stored under or near the appliance, will be subjected to radiant heat and could be seriously damaged.
 - The whole gas system, hose assembly, regulator, pipes, and burner should be inspected for damage and leaks before each use and at least annually by an authorized person for the life of the heater.
 - The hose assembly must be replaced prior to the appliance being put into operation if there is evidence of excessive abrasion or wear, or if the hose is damaged. The replacement hose must be purchased from Bromic Heating Pty Ltd.
 - All leak tests should be done with a soap solution. Never use an open flame to check for leaks.
 - Do not use the heater until all connections have been leak tested.
 - This radiant heater is NOT intended to be installed on recreational vehicles and/or boats.
 - Improper installation, adjustment, or alteration can cause personal injury, property damage, or even death.
- Do not attempt to alter the unit in any manner.
 - Do not paint any surface of the heater or top canopy reflector.
 - Burner and circulation air passageways of the heater must be kept clean. Frequent cleaning may be required as necessary.
 - Turn Gas Supply off when not in use.
 - Check the heater immediately if any of the following occurs:
 - » The heater does not reach temperature.
 - » The burner makes popping noise during use (a slight noise is normal when the burner is ignited or extinguished).
 - This appliance is not intended for use by young or infirm persons unless they have been adequately supervised by a responsible person to ensure that they can use the appliance safely.
 - Check for damage to the appliance regularly. If damage to the appliance is suspected, discontinue use immediately and contact the supplier or qualified person for repair.
 - Avoid inhaling fumes emitted from the heater's first use. Smoke and odour from the burning of oils used in manufacturing will appear. Both the smoke and odour will dissipate after approximately 30 minutes.
 - The pressure regulator and hose assembly supplied with the appliance must be used. Replacement regulator and hose assemblies must be purchased from Bromic Heating Pty Ltd.
 - Storage of an appliance indoors is permissible only if the cylinder is disconnected and removed from the appliance.
 - A cylinder must be stored outdoors in a well-ventilated area out of the reach of children. A disconnected cylinder must have dust caps tightly installed and must not be stored in a building, garage or any other enclosed area.
 - Do not store a spare LP-gas cylinder under or near this appliance;
 - Never fill the cylinder beyond 80% full
 - The heater head angle slip pin must be inserted if transporting the heater to ensure no damage during transit.

PRODUCT OVERVIEW

PRODUCT DESCRIPTION

The TUNGSTEN Gas Radiant Heater is designed to provide effective outdoor heating to both commercial and residential premises whilst offering an appealing design.

The heater incorporates a pivoting head and adjustable heat output for precise heat control. The heater has been designed to withstand the rigors of the outdoors.

SPECIFICATIONS

	TUNGSTEN SMART-HEAT™ PORTABLE
Ignition	1.5V repetitive spark ignitor
Manufactured by	BROMIC PTY. LTD
Approval number	Global-Mark GAS-100177-003
Gas consumption	23.5 Mj/h - 40 Mj/h
Gas Type	Universal LP Gas / Propane Only
Gas Supply	Universal LP Gas Cylinder / Propane Cylinder (9kg or 13.5kg)
Injector size	0.80mm
Weight	56Kg
Safety features	Flame failure device, anti-tilt switch
Gas supply pressure	2.75kPa

TUNGSTEN SMART-HEAT™ HEATER DIMENSIONAL DETAILS

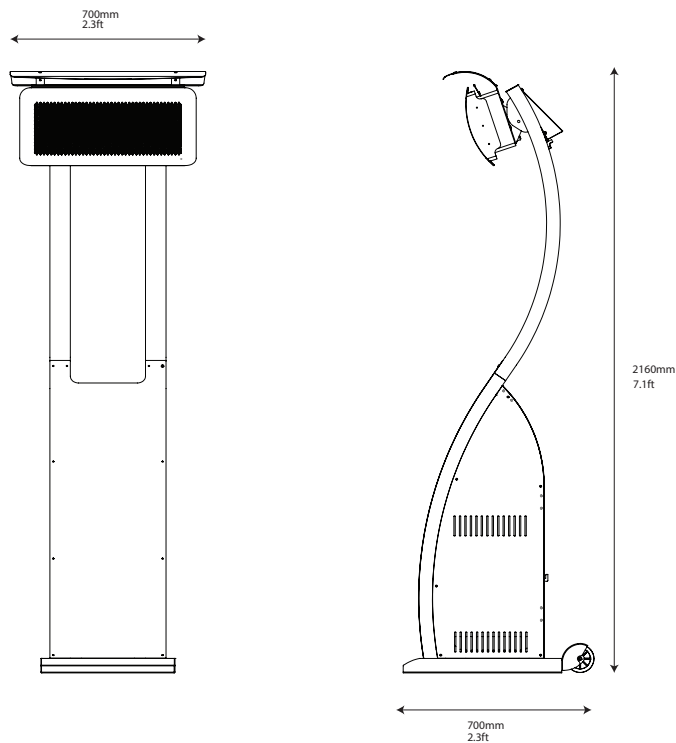

IMPORTANT

This appliance is to be protected from rain. Install under a protective cover.

This appliance shall only be used in an above ground, open-air situation with sufficient natural ventilation. The heater must not be operated in any stagnant areas and should be positioned where any potential gas leakage and products of combustion are rapidly dispersed by wind and natural convection.

GENERAL INFORMATION

The TUNGSTEN Gas Patio Heaters are suitable for outdoor spaces. In addition to the installation Instructions provided, the installer is to ensure that the requirements of the local authority, local gas fitting regulations, municipal building codes, and any other relevant statutory regulations are carried out.

PRODUCT FEATURES

TUNGSTEN Gas Patio Heaters are revolutionizing the outdoor heating industry by introducing ground breaking benefits never seen before in traditional gas or electric heaters. TUNGSTEN heaters have set the industry benchmark with stylish good looks and world-first innovation.

TUNGSTEN heaters excel in the areas of:

- Aesthetic appeal
- Innovation
- Performance
- Flexibility
- Cost effectiveness

For more detailed product information, visit www.bromicheating.com

INSTALLATION REQUIREMENTS

IMPORTANT

This appliance is for outdoor use only.

The appliance must be placed on level firm ground.

This appliance shall only be used in above ground open-air situations with:

- natural ventilation
- without stagnant areas
- where gas leakage and products of combustion are rapidly dispersed by wind and natural convection

Any enclosure in which the appliance is used shall comply with one of the following:

1. An enclosure with walls on all sides, but at least one permanent opening at ground level (ref. Appendix A, Example 1)
2. Within a partial enclosure that includes an overhead cover and no more than two walls (ref. Appendix A, Example 2)
3. Within a partial enclosure that includes an overhead cover and more than two walls, the following shall apply:
 - At least 25% of the total wall area is completely open (ref. Appendix A, Example 4), and
 - At least 30% of the remaining wall area is open and unrestricted (ref. Appendix A, Example 4)
 - In the case of balconies, at least 20% of the total wall area shall be and remain open and unrestricted.

Note: The definition of outdoors is an above ground open-air situation with natural ventilation, without stagnant areas, where gas leakage and products of combustion are rapidly dispersed by wind and natural convection.

GAS REQUIREMENTS

- This appliance is for use with a Universal LP Gas cylinder / Propane cylinder (9kg or 13.5kg) and MUST NOT be connected to a fixed gas supply.
- Regulator outlet pressure to be 2.75kPa.
- The pressure regulator and hose assembly supplied with the appliance must be used. Replacement regulator and hose assemblies must be purchased from Bromic Heating Pty Ltd.
- A dented, rusted or damaged cylinder may be hazardous and should be checked by your gas supplier. Never use an LPG cylinder with a damaged valve connection.
- The LPG cylinder must be arranged to provide for vapour withdrawal from the operating cylinder.
- Never connect an unregulated cylinder to the heater.
- Disconnect the LPG cylinder when the heater is not in use.

LOCATION CLEARANCES

When selecting the location for the TUNGSTEN Gas Patio Heater, the following clearances should be followed.

Care should be taken to ensure that the heater is not installed:

- Where heat/ignition can cause damage to gas cylinders/lines
- Near other combustible materials
- In open locations subject to rain

Note: Heater should be installed in such a way so as to allow adequate;

- Clearance around air openings to combustion chamber
- Clearance from combustible material
- Provisions for accessibility and clearance for combustion and ventilating air supply.

IMPORTANT

This appliance must only be used in a well ventilated area.

When selecting the installation location for the Tungsten Smart-Heat Portable, the following clearances should be followed.

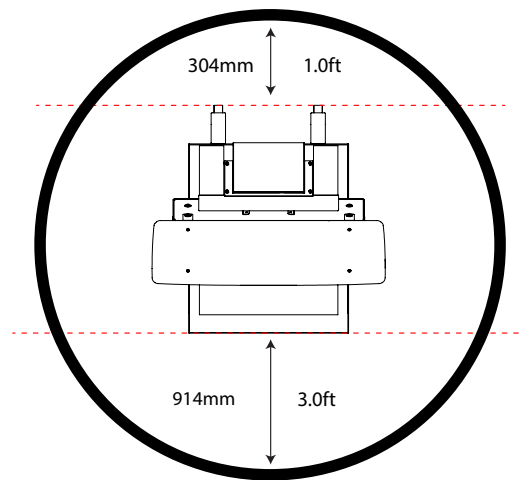
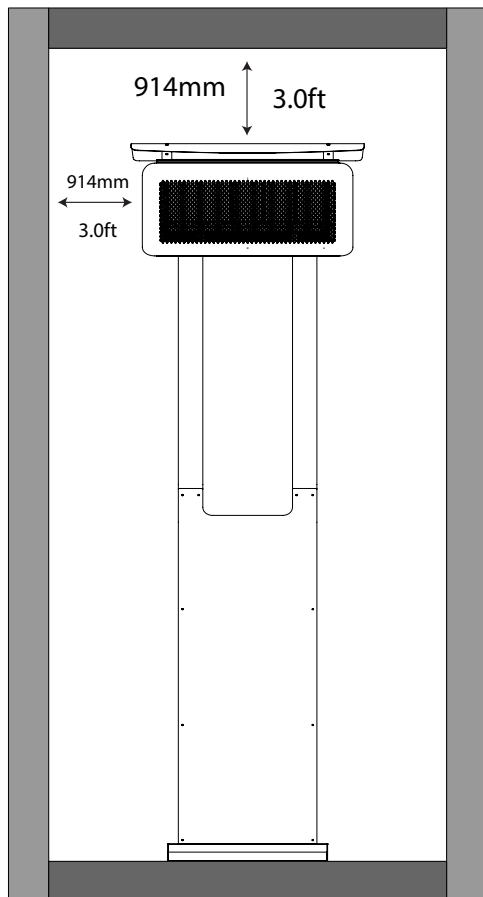

INSTALLATION INSTRUCTIONS

CONTENTS PACKED IN (2) BOXES

Box 1 Contents

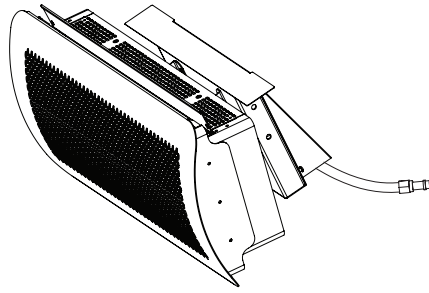

Head Assembly



AAA Battery

Box 2 Contents

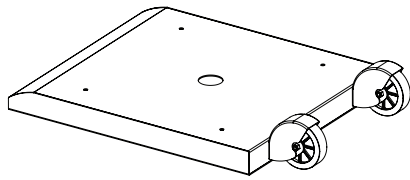

Base Assembly

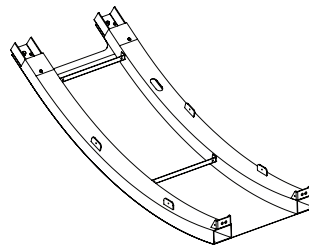

Front Assembly

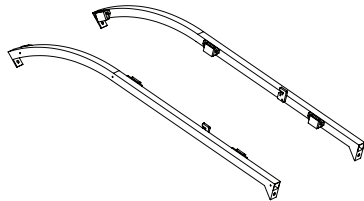

Rear Arm Assembly x 2

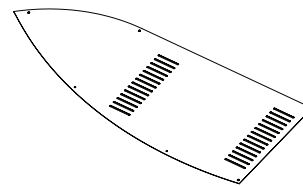

Side Panels x 2

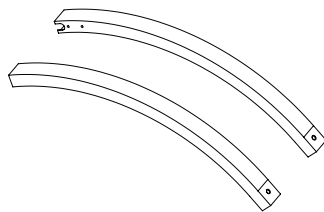

Top Arms x 2

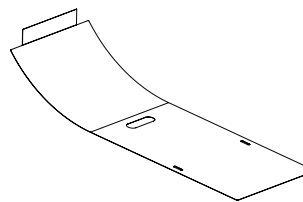

Rear Cover

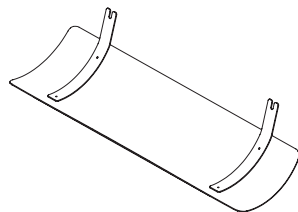

Top Flame Deflector

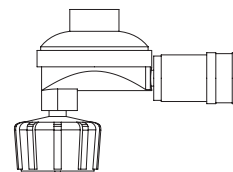

Regulator

Supplied Fasteners

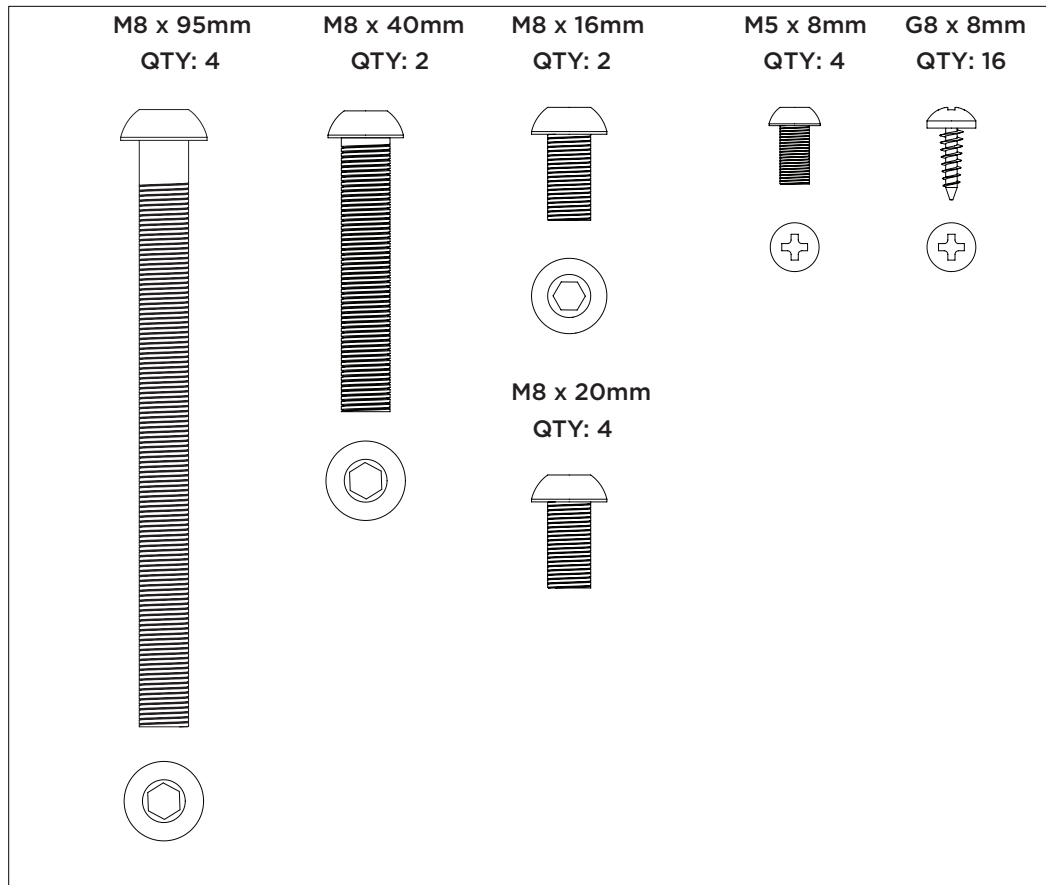

Supplied Tools

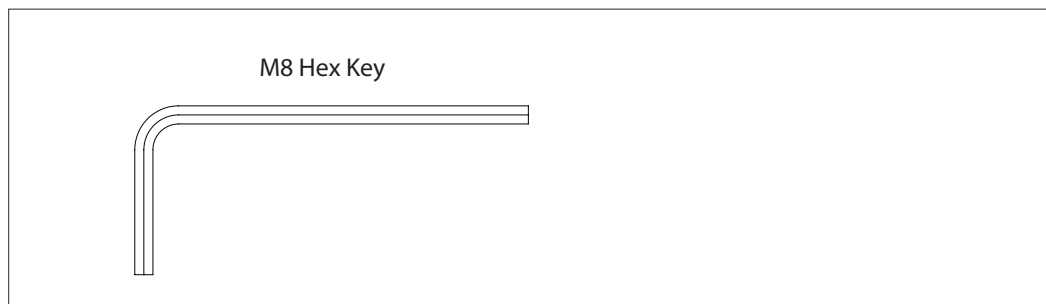

Tools Not Included

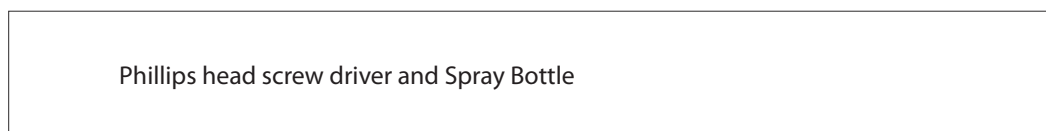

STEP 1:

Unpack boxes and place all items on a non abrasive surface.

STEP 2:

Fasten rear arms to base using 2 x M8 20mm screws and the supplied M8 Hex Key.

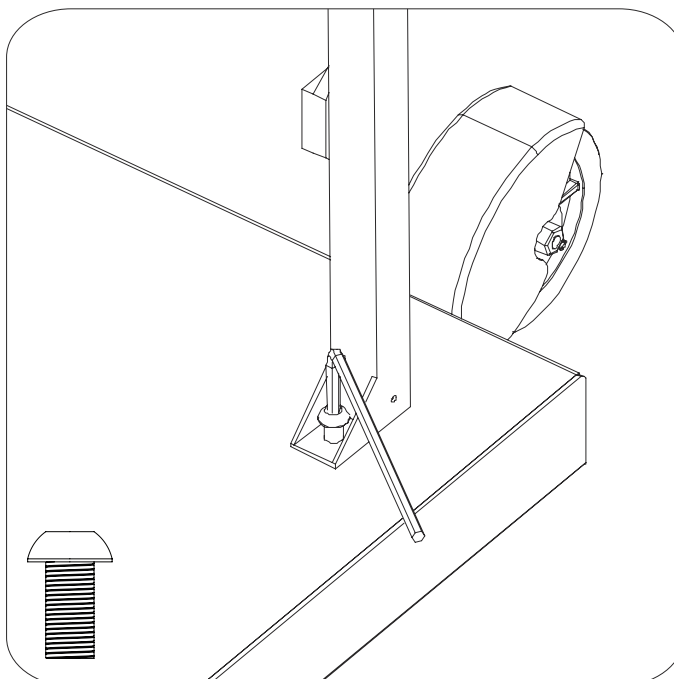
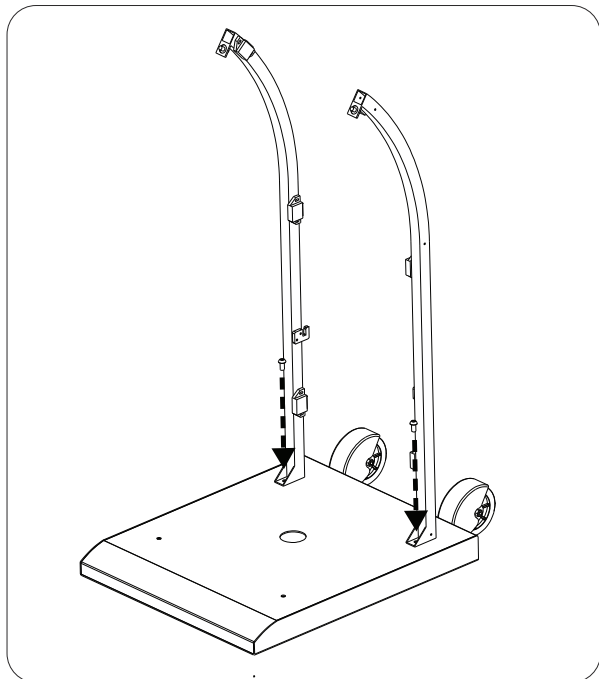

STEP 3:

Position front assembly and fasten using 2 x M8 20mm screws using supplied M8 Hex Key.

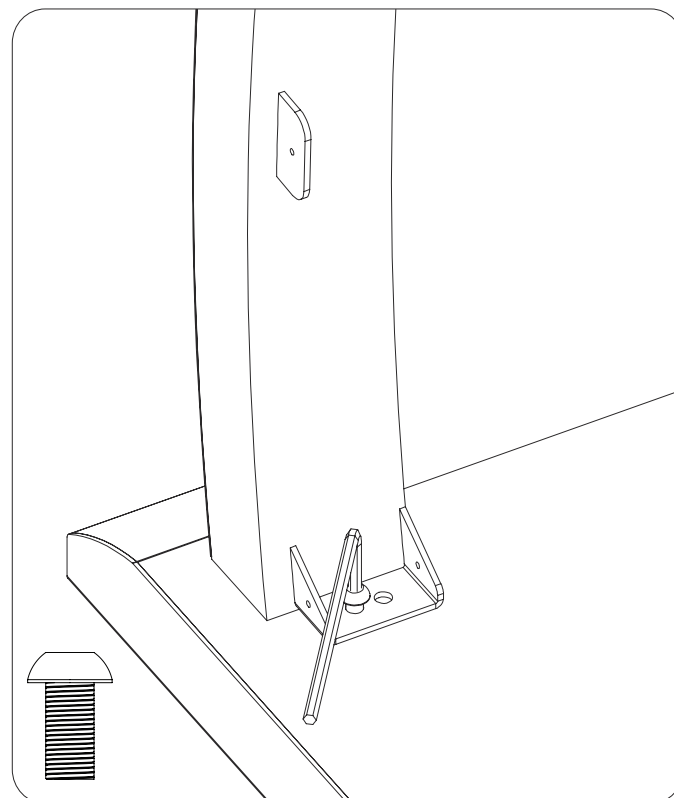
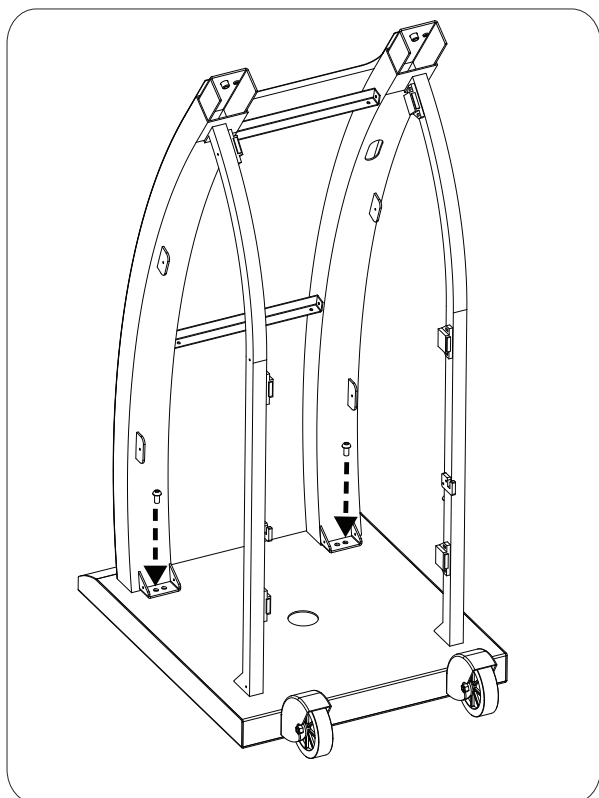

STEP 4:

Secure the rear arms to front assembly using 2 x M8 x 16mm screws and supplied M8 Hex Key.

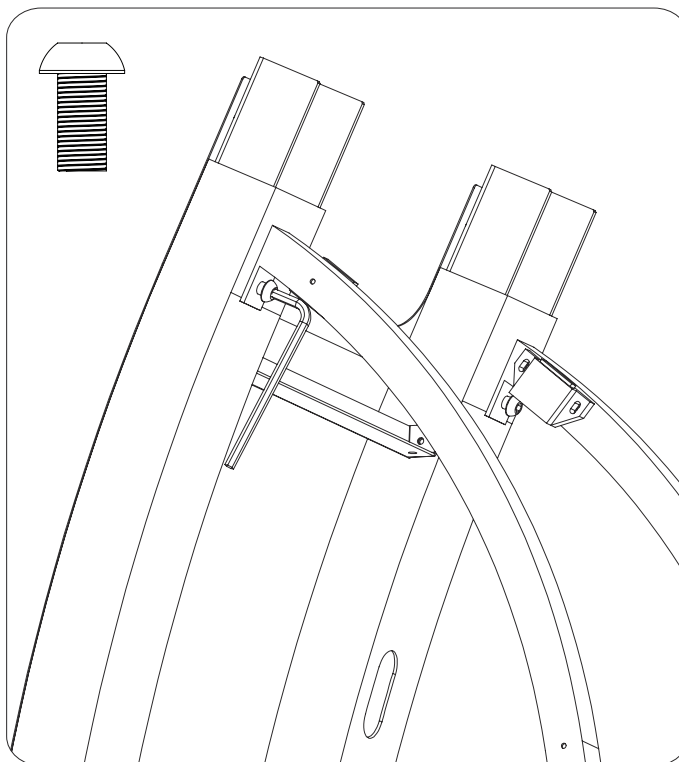
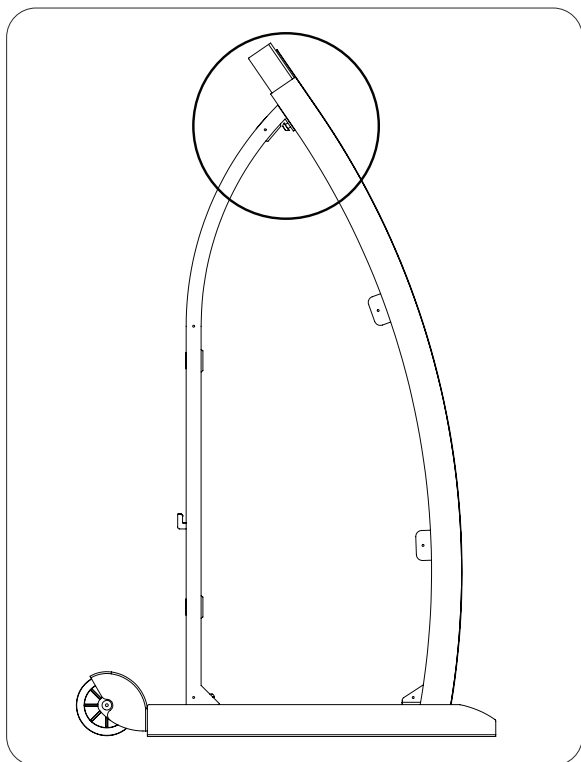

STEP 5:

Secure the side panels to frame using 12 x G8 screws - A Phillips screw driver is required for this step. Repeat for opposite side.

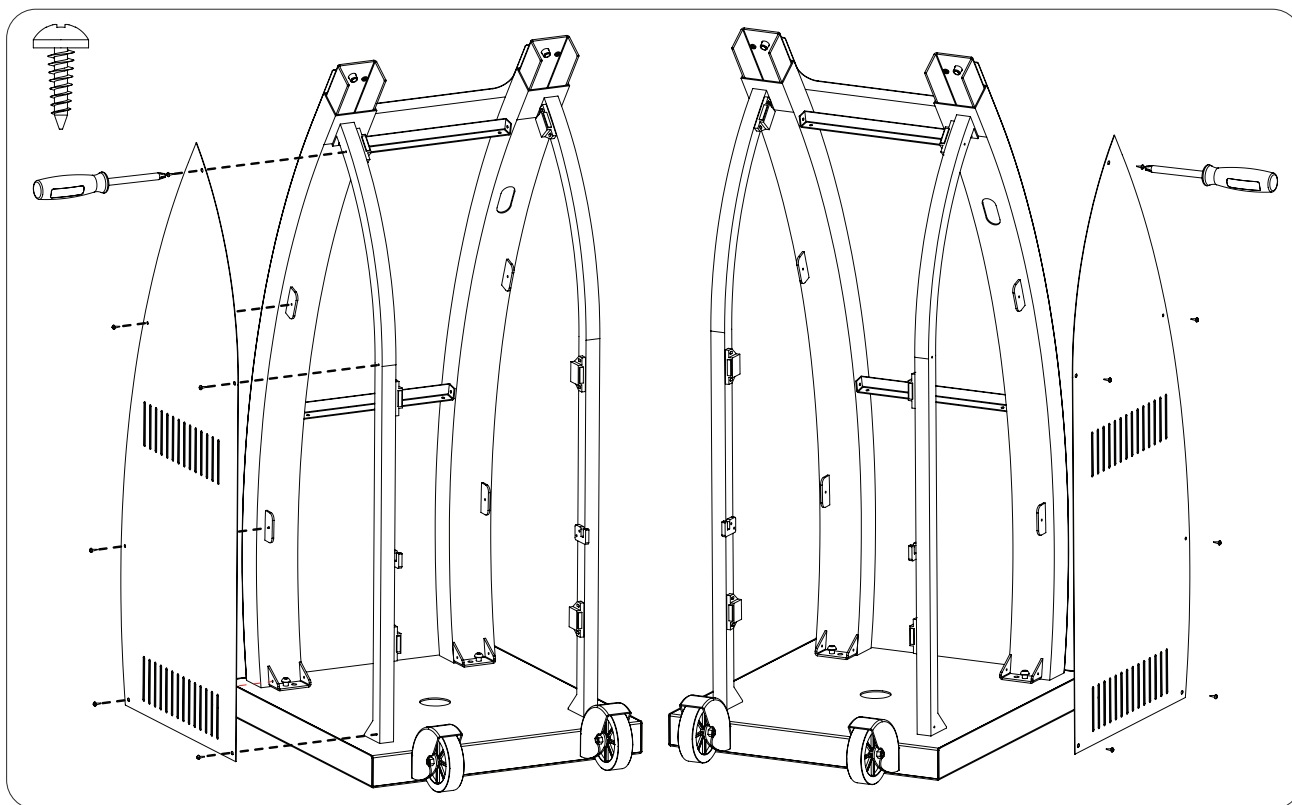

STEP 6:

Slide top arms over front assembly slip joints - Ensure top screw holes are faced inwards.
Secure the front panel to top arms using 4 x M5 screws.

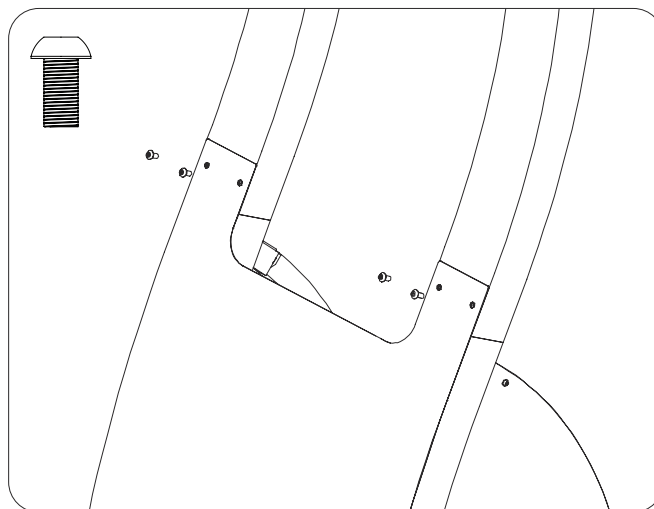
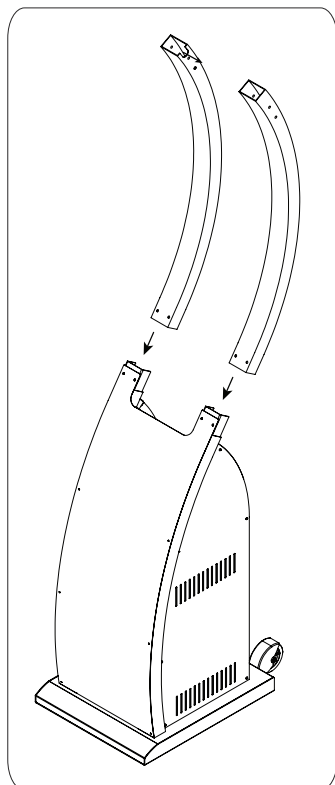

* Note: The joint between the lower and upper arms is firm to ensure rigidity and stability of the product. To engage slowly lever the two sections together using some force and push down fully

STEP 7:

Secure the top arms to lower arm slip joint using 2 x M8 x40 screws and supplied M8 Hex Key.

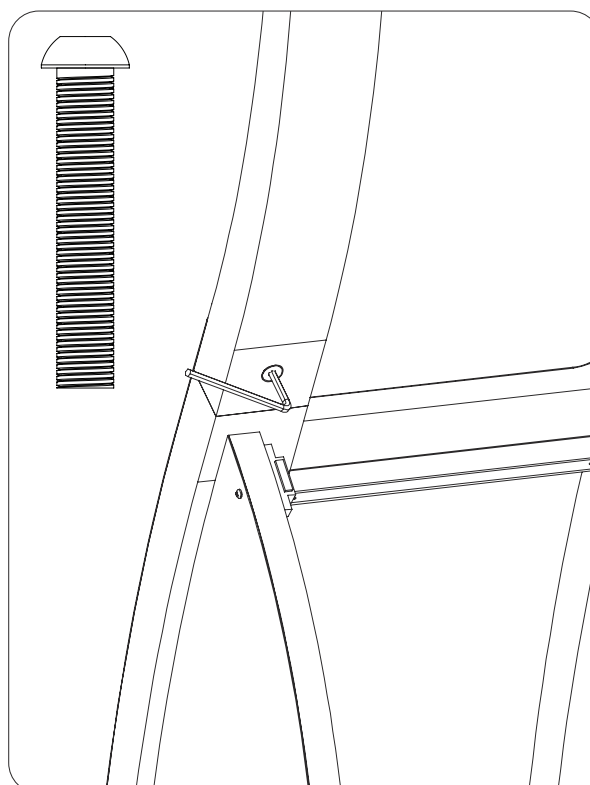
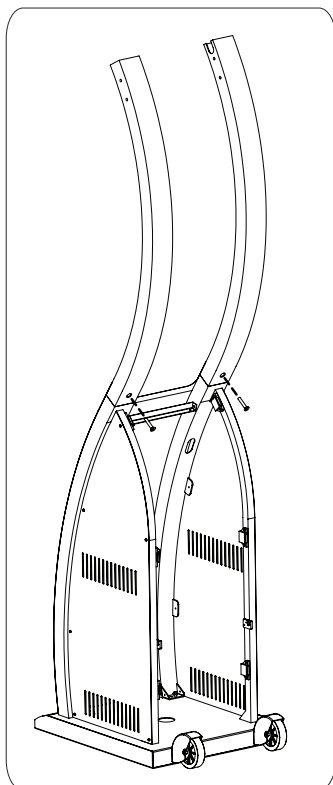

STEP 8:

Lay both heater head and stand on a non abrasive surface as shown. Two people are required for this step.

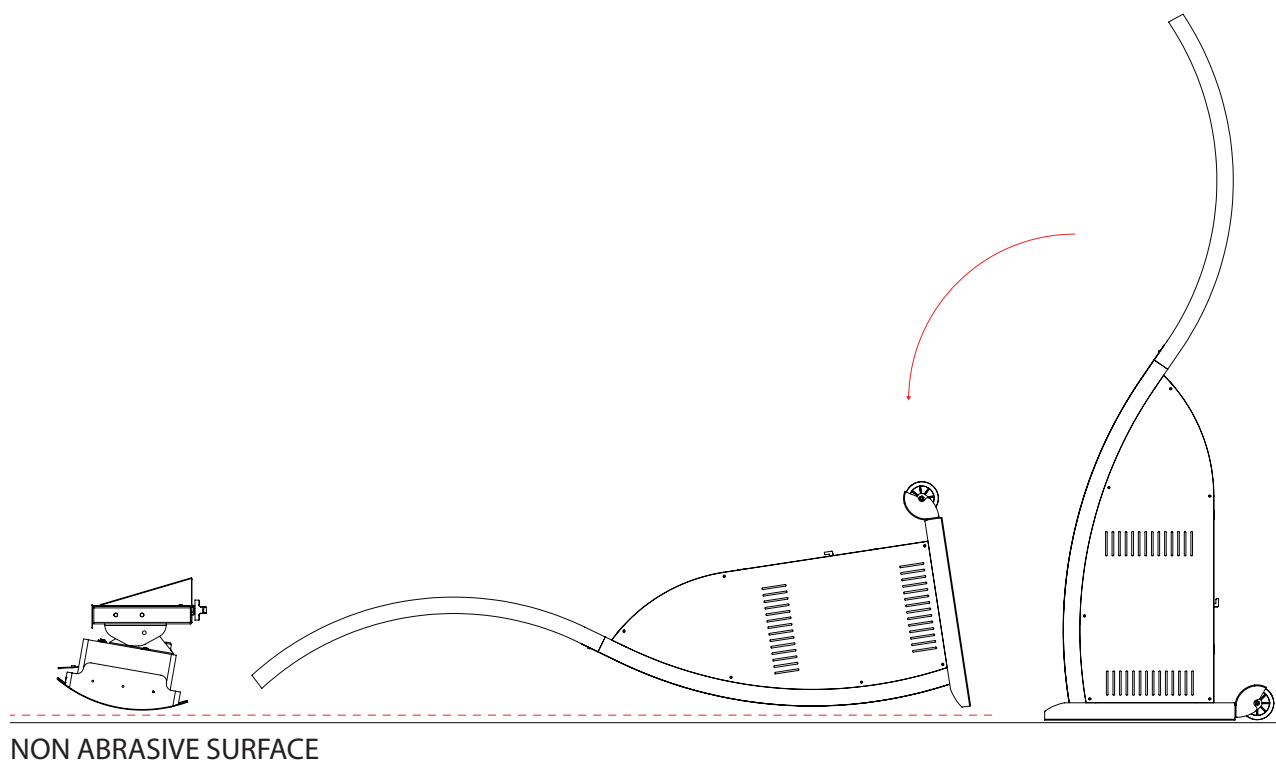

STEP 9:

Feed gas hose through arm slot and push through until it reaches slot in bottom arm. Keep feeding hose until all slack is taken up.

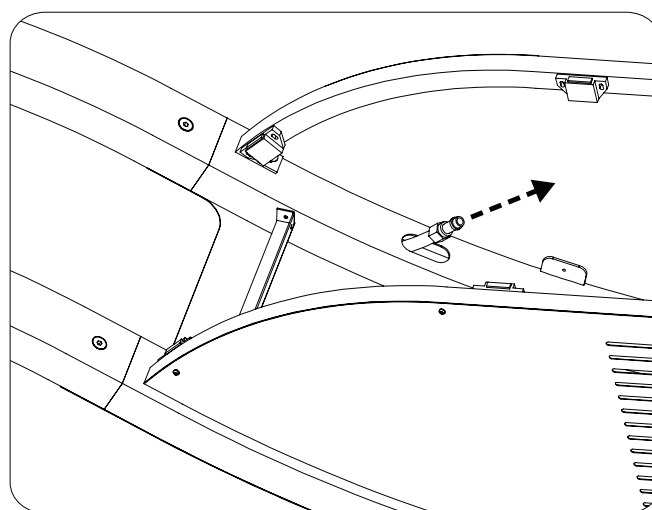
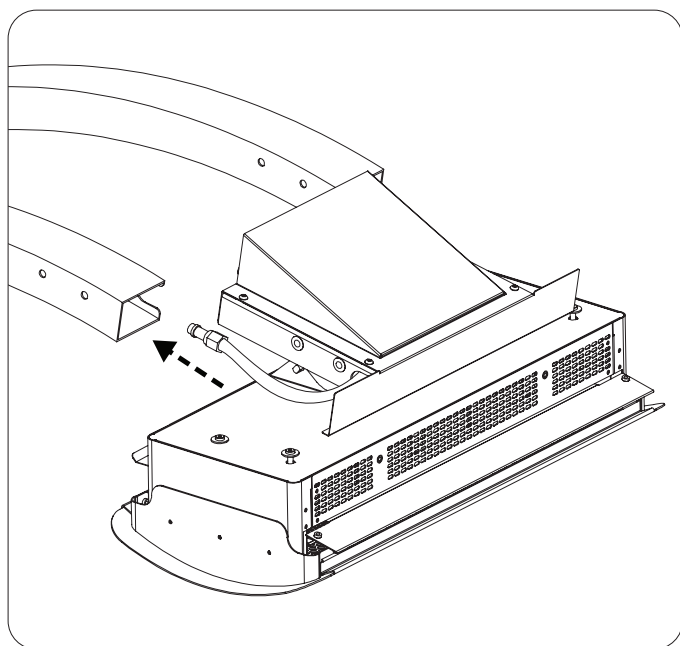

STEP 10:

Secure the heater head to arms using 4 x M8 screws and supplied washers

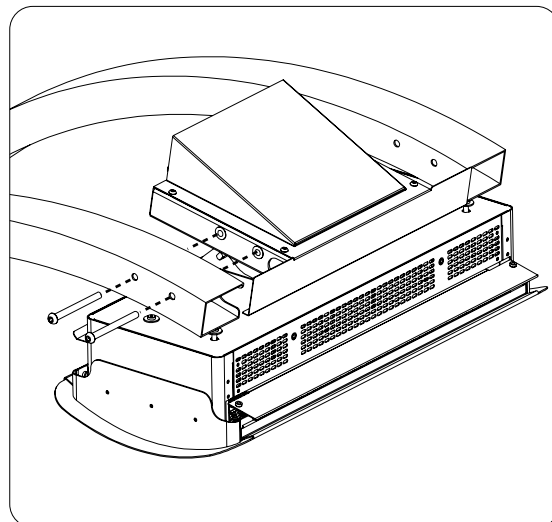

STEP 11:

Return heater to upright position.
Two people are required for this step.

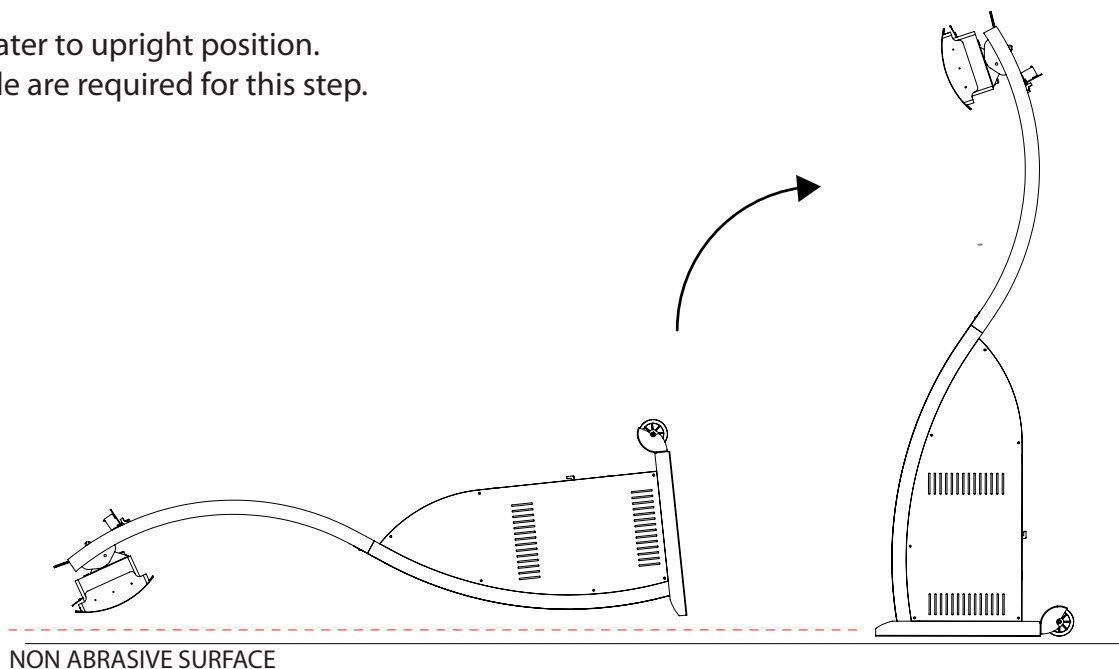

STEP 12:

Fill base with fine grain sand (this sand can be purchased from most hardware stores). Entry point for the sand is the hole at the centre of the base.

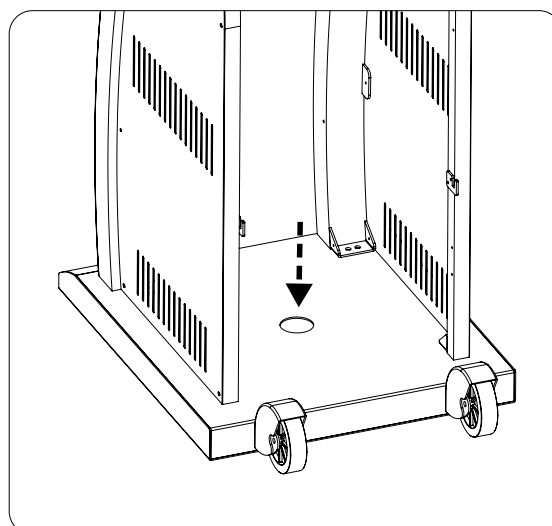

STEP 14:
Screw regulator assembly
to gas bottle.

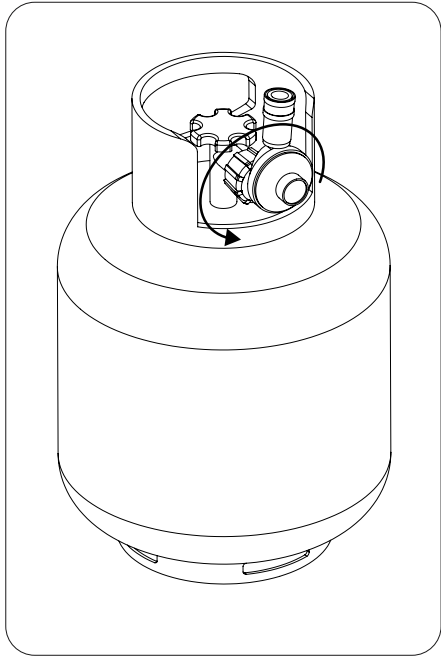

STEP 15:
Place gas bottle into lower enclosure and fasten
strap tightly.

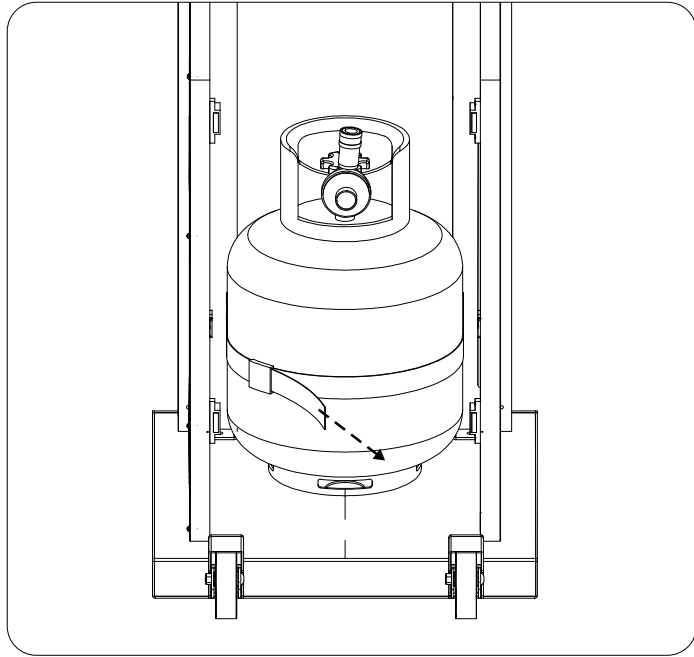

STEP 16:
Pull sleeve back on regulator
connector, insert hose fitting &
release sleeve on regulator
connector.

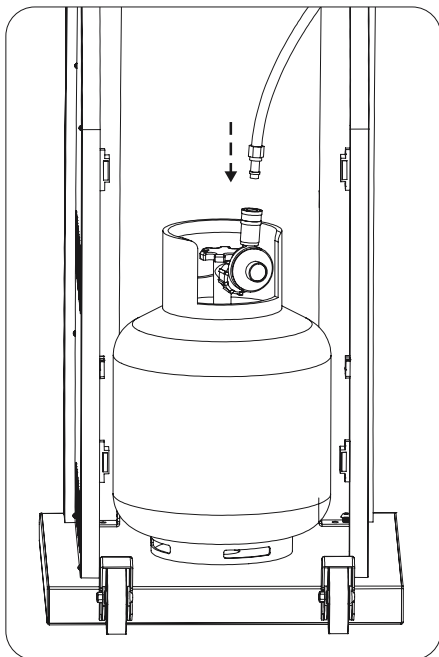

STEP 17:
Lower gas bottle bracket into position.

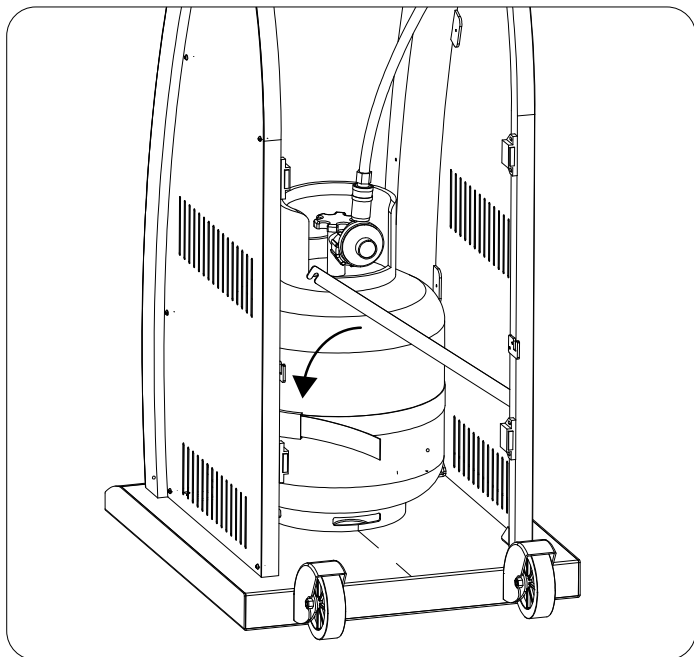

STEP 18:

Secure deflector to heater by loosening the two screws and secure brackets underneath washers. Re-tighten screws to original position using screw driver.

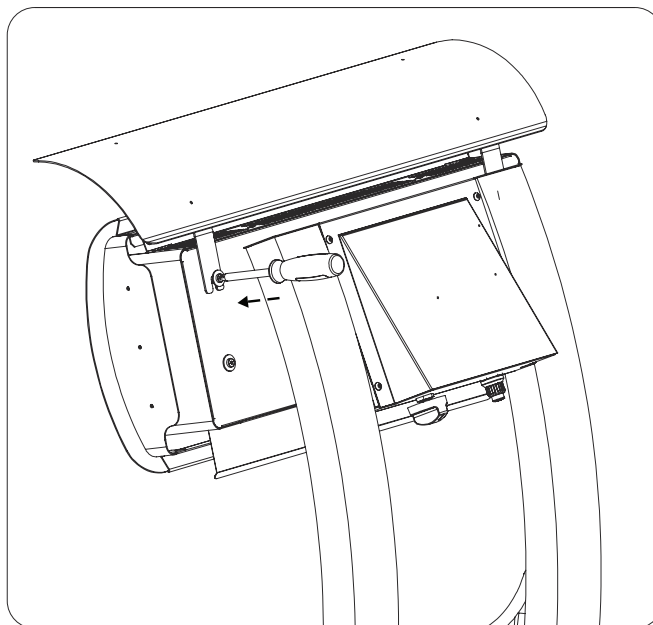
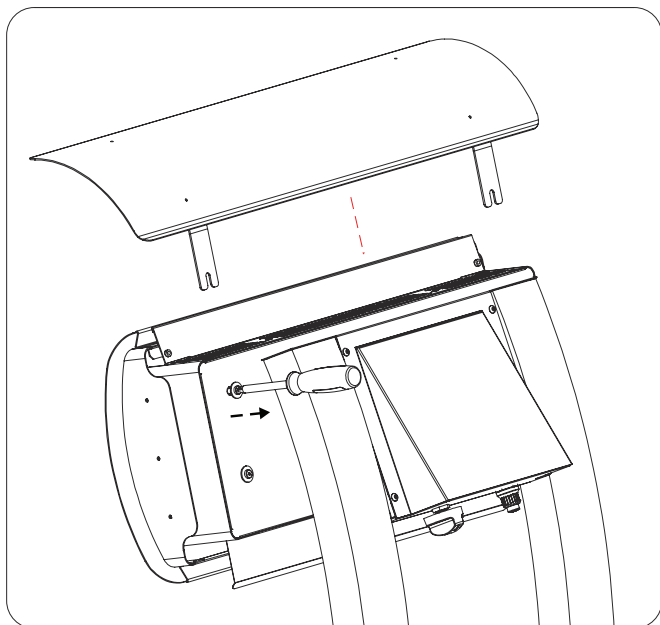

STEP 19:

Unscrew igniter cap. Insert supplied AAA battery into cap and re-screw to original position

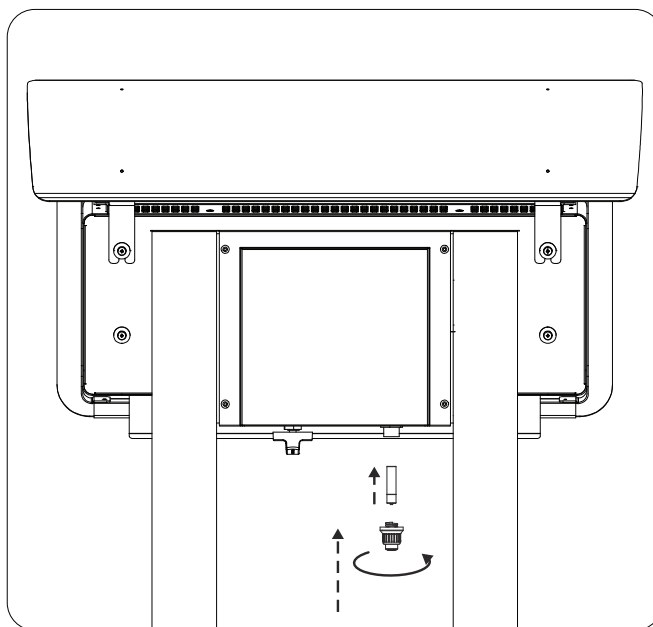
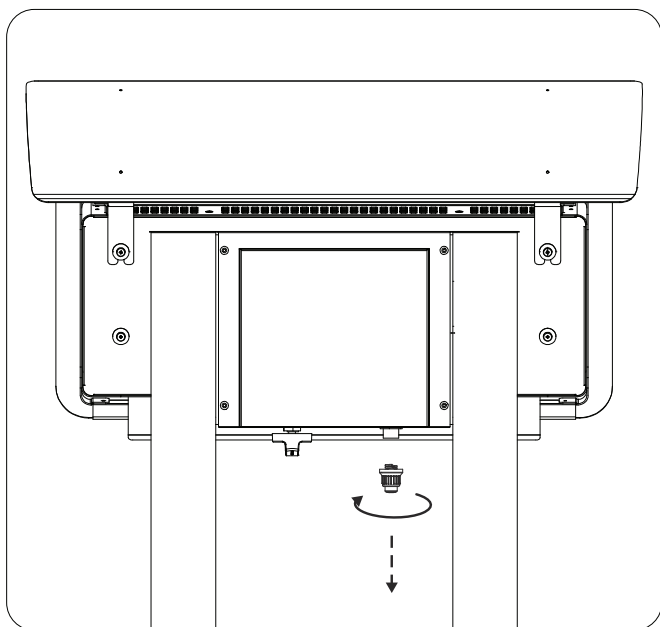

STEP 20:

Perform Gas leakage test as shown on page 20

STEP 21:

Secure the top piece of rear cover to frame using 4 x G8 screws - A Phillips screw driver is required for this step.

The bottom piece of rear cover is secured by magnets. Firstly position slots in back cover over the two hooks then lower cover to allow magnets to catch

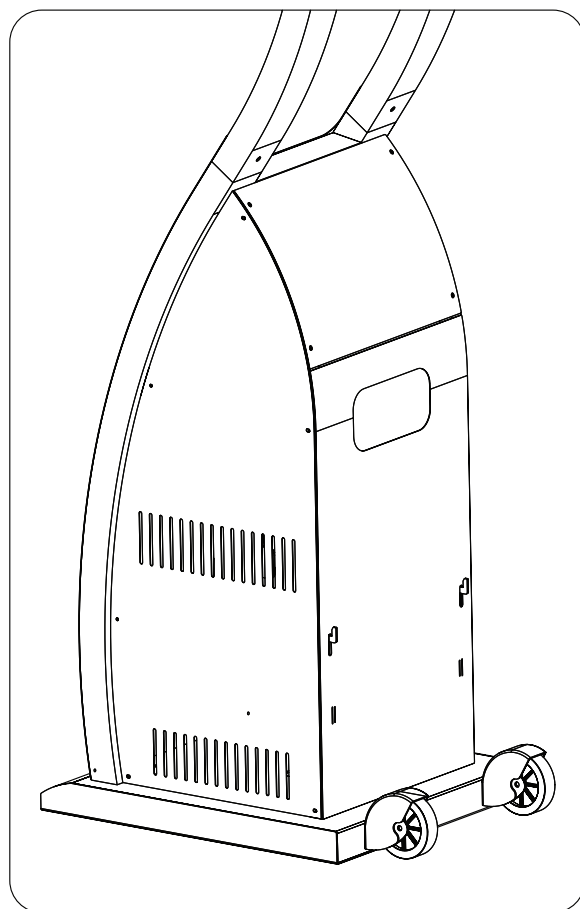
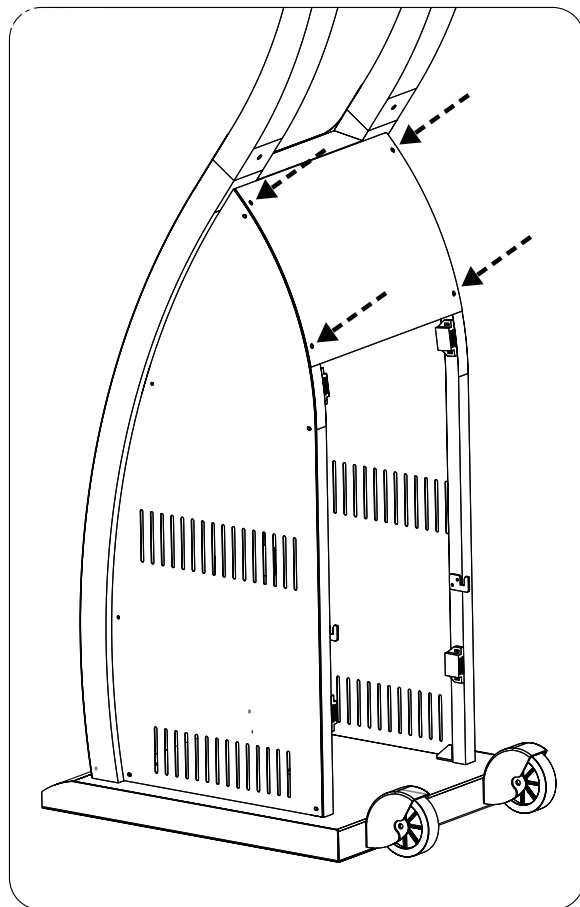

Adjusting the heater head angle

CAUTION: ONLY ADJUST THE HEATER HEAD ANGLE PRIOR TO OPERATION. ADJUSTING WHILST UNIT IS IN OPERATION OR POST OPERATION CAN CAUSE SERIOUS BURNS

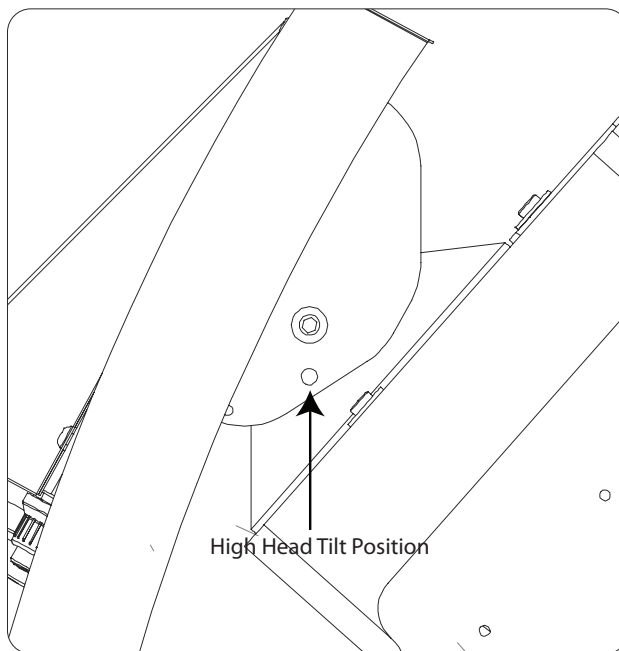
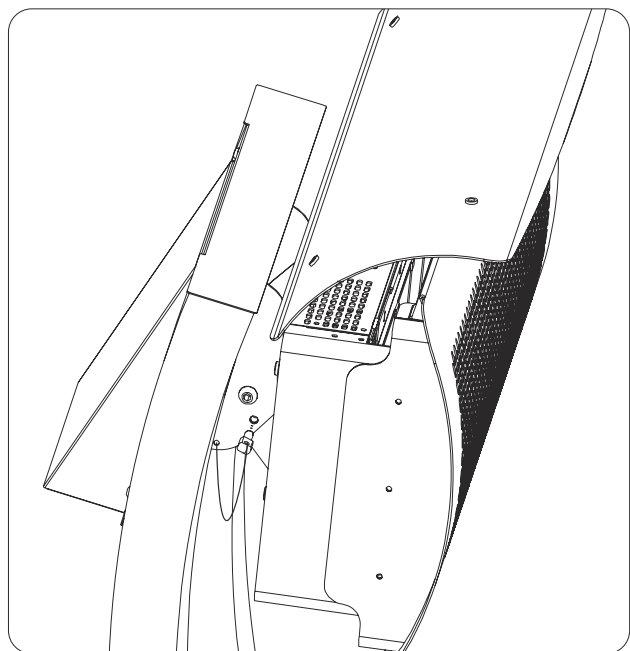

To set heater head angle at high position, manually push heater head up to align hole then insert slip pin.

To set heater head angle at low position, remove slip pin & allow heater head to rest in low position. Slip pin does not need to be inserted.

Note:

The slip pin must be inserted if transporting the heater to ensure no damage during transit.

LEAK TEST

Gas connections on heater are leak tested at the factory prior to shipment. A complete gas leak test must also be performed after assembly before operating the heater due to possible damage occurring during transportation.

- Never leak test while smoking.
- The heater must be checked with a full gas cylinder.
- Ensure connection all 3 connections illustrated below are connected correctly & tight.
- Make sure the control knob is in the OFF position.
- Make a mild soapy water solution. The soapy solution can be applied with a spray bottle, or soft cloth.
- Turn on the gas supply at the gas cylinder.
- Apply the soapy water solution to the 3 connections illustrated below.
- To check connection #3 the gas control knob must be pressed in to open the gas valve.
- If bubbles appear at any of the connections, there is a gas leak.
- If a gas leak is detected, turn off the gas supply. Tighten any leaking fittings, and repeat process described above.
- If soap bubbles still appear (gas is still leaking), turn off the gas supply at the cylinder, disconnect the regulator from the gas cylinder, and contact the store of purchase for assistance and advice.
- If gas connections are gas tight, the heater is ready to be used.

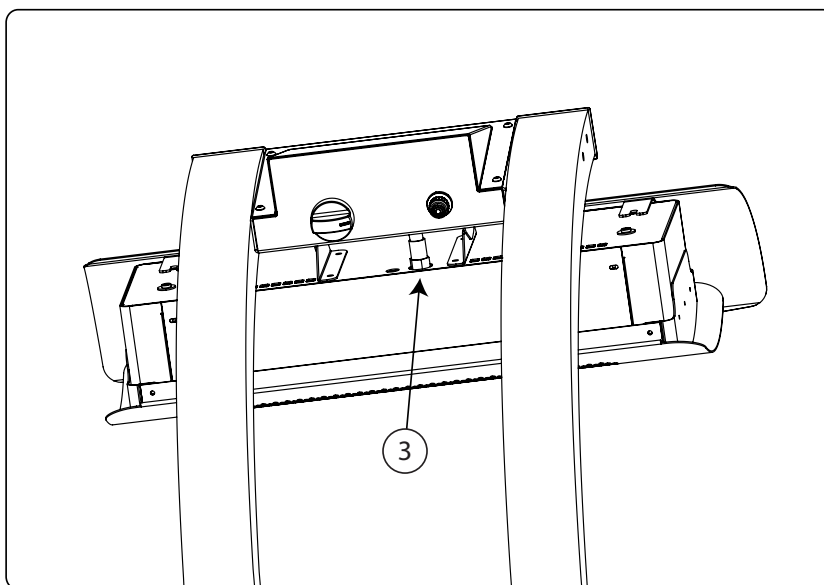
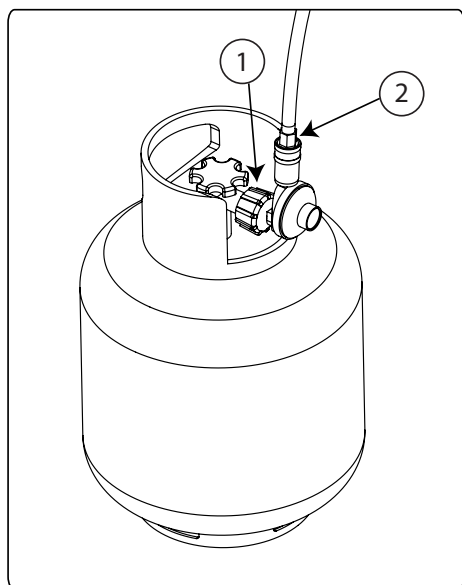

TURNING THE APPLIANCE ON

1. Ensure that installation has been carried out in accordance with the manufacturers instructions outlined in this document.
2. Test the spark ignite button is working correctly by pressing the button and observing sparks at the ignition rods at the front of the heater. If sparks are not observed do not proceed with turning appliance on. Contact the store of purchase for assistance and advice.

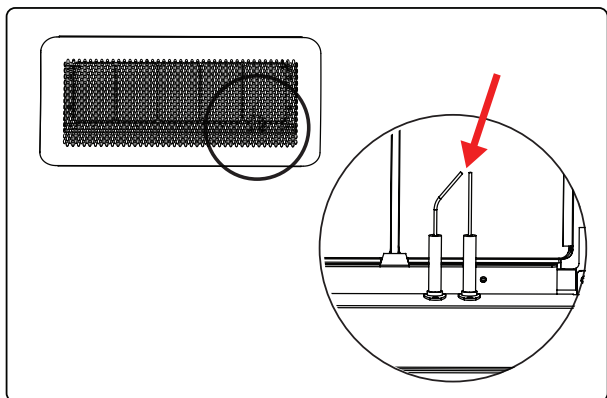

⚠ WARNING

Do not turn the heater on with people standing in front of heater. Heater must be turned on while standing behind the heater.

⚠ WARNING

Improper lighting procedures can cause personal injury, property damage, or even death.

3. Turn ON the gas supply at the LPG storage bottle.
4. Turn on gas control knob to maximum setting

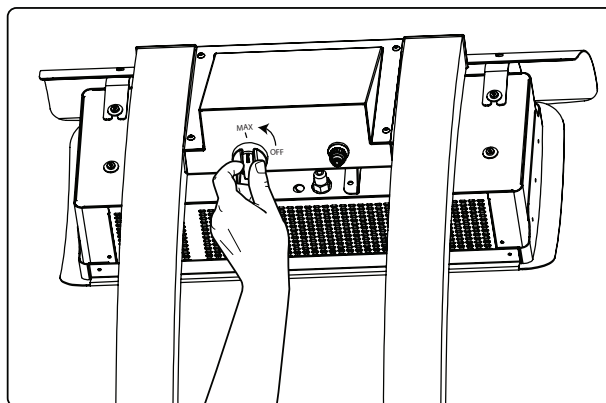

5. Push in and hold control knob whilst simultaneously pressing the spark ignite button. Continue to hold in the controls for 10 seconds for ignition to complete.

Release the controls. If the heater has not ignited wait 5 minutes and then repeat Step 5.

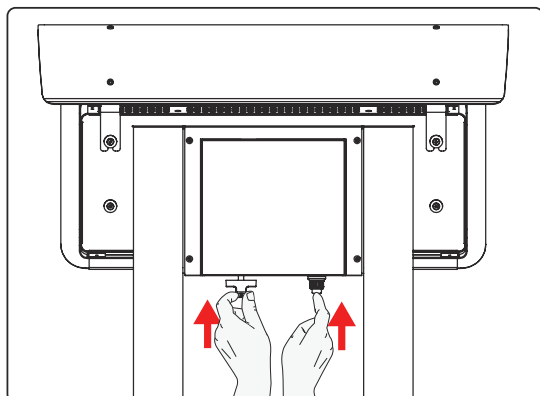

6. When appliance is correctly turned on the tiles will start to glow red.



TURNING THE APPLIANCE OFF

1. Press and turn the control knob to "OFF" position to stop the supply of gas to the burner. The tiles should change colour from red to black.

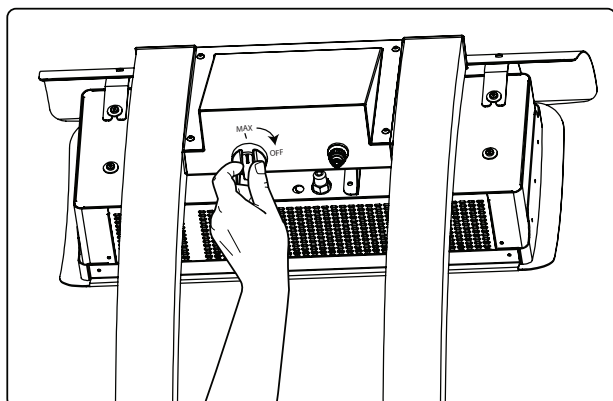

2. Turn OFF the gas supply at the LPG storage bottle.
3. WARNING - After turning heater off, you must wait a minimum 5 minutes to let excess gas dissipate before lighting again.

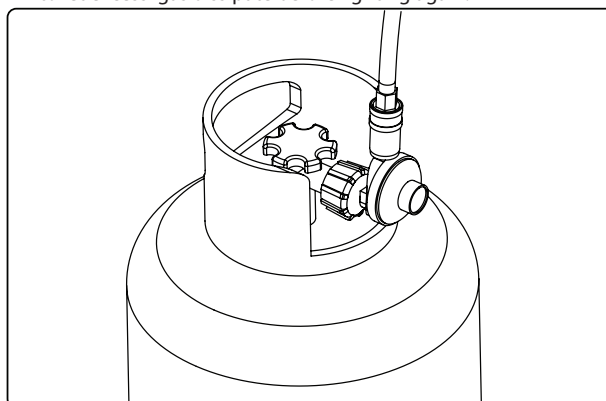

MAINTENANCE AND SERVICING

It is important that regular maintenance is carried out on the heater to maintain efficient operation. All maintenance should be carried out ONLY by authorized service personnel. Inspect and clean at least every six months or more frequently in adverse conditions.

Never obstruct the flow of combustion and ventilation air. Always keep the appliance area clear and free from combustible materials, gasoline and other flammable vapors and liquids. Do not clean heater with cleaners that are combustible or corrosive.

REGULAR SERVICE REQUIREMENTS

1. The whole gas system, hose assembly, regulator, pipes, and burner should be inspected for damage and leaks before each use and at least annually by an authorized person for the life of the heater. To check the gas hose within the mounting arm, disassemble heater by reversing the installation instructions as outlined in installation section of this manual. The hose assembly must be replaced prior to the appliance being put into operation if there is evidence of excessive abrasion or wear, or if the hose is damaged. The replacement hose must be purchased from Bromic Heating Pty Ltd.
2. VISUALLY CHECK BURNER FLAMES.
During heaters function visually check that all burners are alight and glowing hot. This can be done by observing the red glow through the translucent face, or by peering down the product combustion passageway. Note: A slight variation in colour is to be expected.

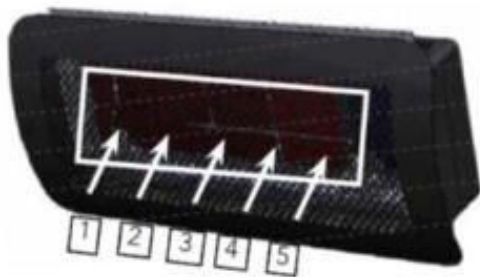

3. Clean burners: Burners can be cleaned by directing compressed air (max20PSI) at outlet ports. Avoid directing air at gasket material between ceramic tile and burner cup.
4. Clean manifold and injectors: Undo gas hose from gas valve outlet (heater should be switched off) and inject compressed air (max20PSI) down the inlet fittings.
5. Clean dust and foreign matter from inside of heater housing: Open up rear housing and clear dust using compressed air (max20PSI) and a damp cloth.
6. Remove debris, spider and insect nests from, control compartment, burner and circulation air passageways of the heater with heavy-duty pipe cleaner or compressed air to keep appliance clean and safe for use. Never clear ports or other openings with toothpicks or other articles that will break and block the ports.
7. In a salt-air environment, such as near an ocean, corrosion occurs more quickly than normal. Remove salt spray from the heater immediately to prolong heater life. Check frequently for corroded areas and repair them promptly.
8. The exterior components of the heater are constructed from stainless steel, and high temperature black paint.

9. Over the life of the heater internal non-painted parts may slightly discolour from high temperatures emitted by the heater. This is a normal occurrence and does not affect the operation of the appliance.
10. Replacement parts can be purchased to restore the heater to its original appearance from Bromic Heating Pty Ltd.

⚠ IMPORTANT

Service and repair should be done by a qualified service person.

The heater should be inspected before use and at least annually by a qualified service person.

More frequent cleaning may be required as necessary. It is imperative that control compartment, burners and circulating air passageways of the heater be kept clean.

⚠ IMPORTANT

Do not apply any additional surface coating to the heater under any circumstances. Use of additional coating other than those applied during manufacture could result in hazardous reactions such as toxic fumes or fires. Additional coatings will void the warranty.

STORAGE

- There is no limitation on the storage of appliances indoors provided that the cylinder is removed from the appliance.
- Storage of an appliance indoors with the cylinder attached is only permitted if the size of the cylinder complies with AS/NZS 1596; otherwise cylinders must be stored outdoors in a well-ventilated area.
- Always close the gas valve on the gas cylinder after use.
- Remove the pressure regulator and hose assembly.
- Cylinder must be stored outdoors in a well-ventilated area out of the reach of children.
- Disconnected cylinders must have threaded valve plugs tightly installed and must not be stored in a garage or any other enclosed area.
- Check the tightness of the gas valve and for damage. If you suspect you have a damaged gas cylinder valve, contact your place of purchase.
- Only store gas cylinders in places with adequate air ventilation.

REPLACEMENT PARTS

An authorised service technician MUST replace any faulty items with the correct approved component from the list below. Contact your place of purchase to organise any of the replacements parts below.

No:	Description	Part No:
1	Control Knob	2620352
2	Gas Valve	2620353
3	Ignition Pack	2620354
4	Cylinder Housing - Rear Cover	2620355
5	Cylinder Housing - Side Panel	2620356
6	Inner Mesh	2620357
7	Cylinder Housing - Front Panel Assembly	2620358
8	Burner Box	2620359
9	Thermocouple Assembly	2620360
10	Front Cover	2620361
11	Ignition & Earth Rod Assembly (Inc. Wiring Harness)	2620362
12	Heat Deflector Assembly	2620363
13	Wheel Kit (Left & Right Set)	2620364
14	Screw Set	2620365
15	Cylinder Housing - Rear Arms With Magnets	2620366
16	Rubber Ring (From Rear Cylinder Cover)	2620367

TROUBLESHOOTING

Problem	Possible cause	What you can do (if these do not work, contact an authorised technician)	What ONLY an authorised service technician can do
Burner will not light	<ul style="list-style-type: none"> • Gas valve may be OFF • Tank fuel empty • Opening blocked • Loose connections • Low gas pressure • Thermocouple bad • Not in correct location 	<ul style="list-style-type: none"> • Turn the gas valve ON • Check all fittings • Replace cylinder with a new cylinder 	<ul style="list-style-type: none"> • Refill LPG tank • Remove and clean • Replace thermocouple
Burner will not stay on	<ul style="list-style-type: none"> • Loose connections • Thermocouple bad • Gas leak in line • Lack of fuel pressure • Tank near empty 	<ul style="list-style-type: none"> • Tighten connections • Check connections 	<ul style="list-style-type: none"> • Clean dirty area • Replace thermocouple • Refill LPG tank.
Burner flame is low	<ul style="list-style-type: none"> • Supply hose is bent or twisted 	<ul style="list-style-type: none"> • Straighten hose and perform leak test on hose 	
Emitter glows uneven	<ul style="list-style-type: none"> • Low gas pressure • Base is not on a level surface 	<ul style="list-style-type: none"> • Replace cylinder with a new cylinder • Place heater on a level surface 	
Thick black smoke	<ul style="list-style-type: none"> • Blockage in burner 	<ul style="list-style-type: none"> • Turn off the heater and let it cool. 	<ul style="list-style-type: none"> • Remove blockage and clear burner inside and outside
Carbon build-up	<ul style="list-style-type: none"> • Dirt or film on reflector and flame screen 	<ul style="list-style-type: none"> • Clean reflector and flame screen 	

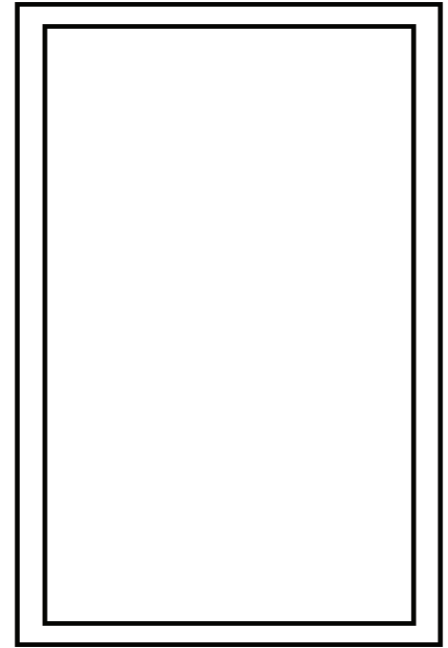
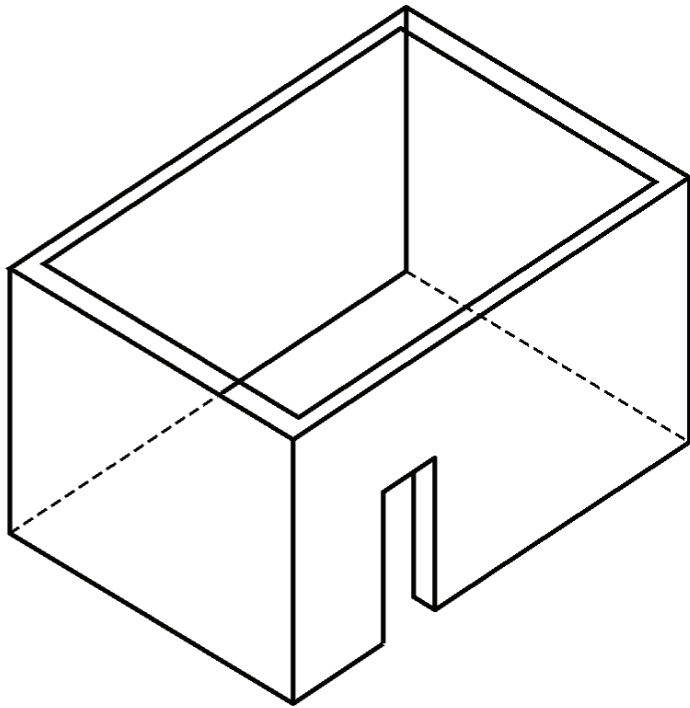

OUTDOOR AREA-EXAMPLE 1

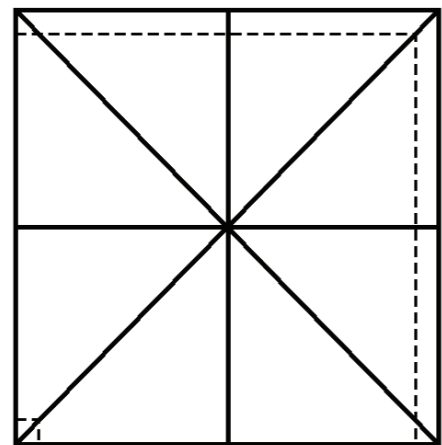
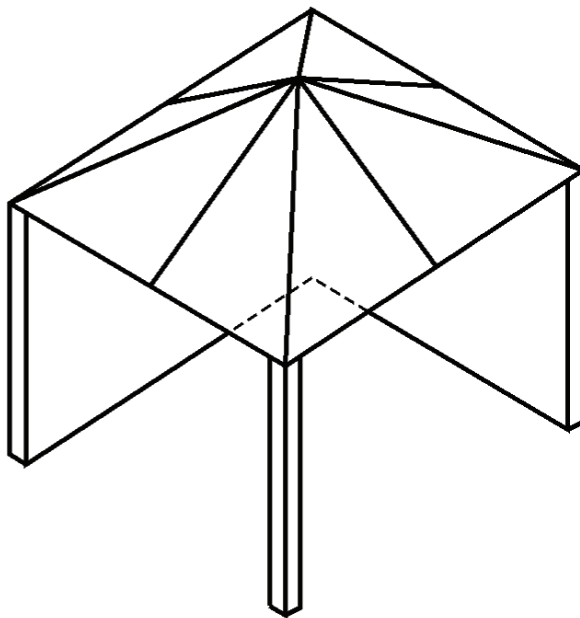

OUTDOOR AREA-EXAMPLE 2

Both ends open

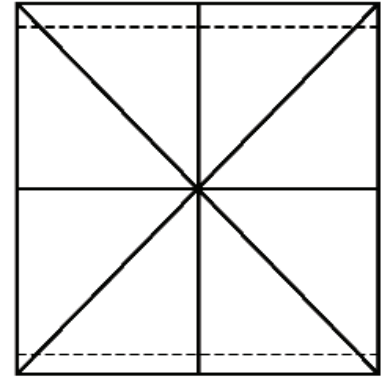
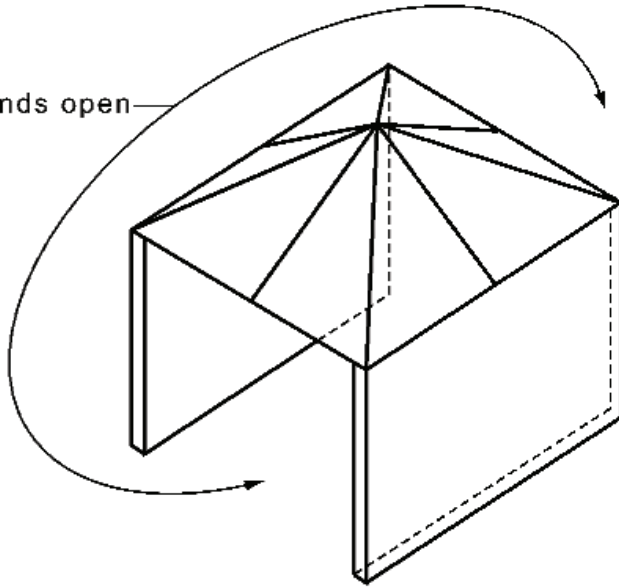

OUTDOOR AREA-EXAMPLE 3

Open side at least 25% of total wall area

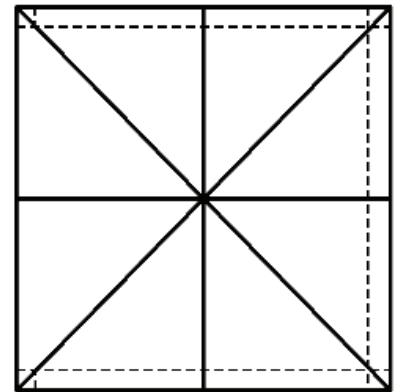
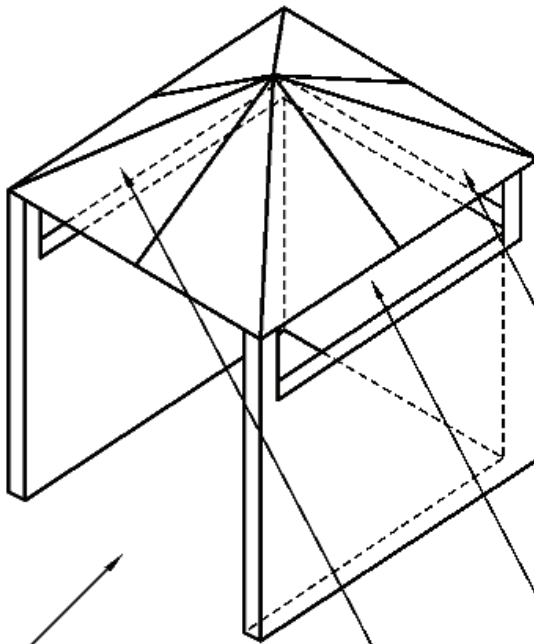

30 percent or more in total of the remaining wall area is open and unrestricted

OUTDOOR AREA-EXAMPLE 4

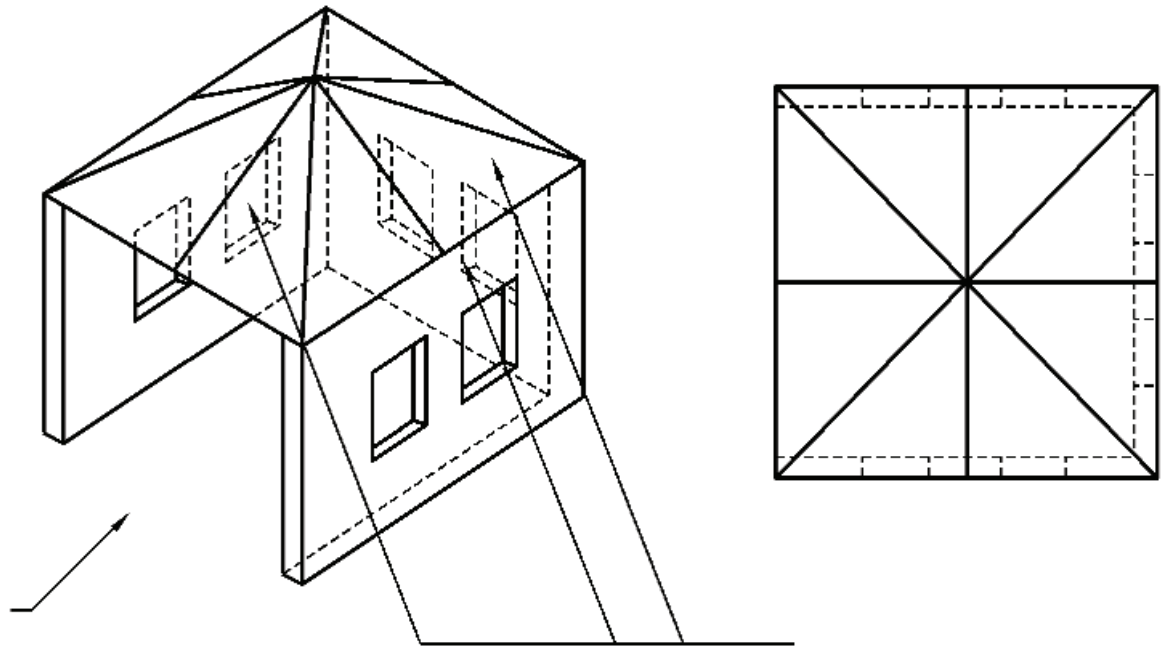

Smart-Heating Warranty Conditions

Bromic Pty Limited ('Bromic') warrants to the original purchaser ('the Purchaser') of products supplied by Bromic Heating ('the Goods') that the Goods will be free from defects and/or faults in materials and/or workmanship for Twelve (12) months from the date of Bromic invoice.

Subject to the following conditions of this Warranty, if a defect and/or fault in materials and/or workmanship are found during the warranty period, Bromic will replace or repair the Goods (at its option) without charge.

1. The Goods must have originated from Bromic and must be able to be identified by Bromic personnel as a Bromic Heating product.
2. The original invoice details, including serial number where applicable, MUST be provided to Bromic at the time that any claim is made pursuant to the terms of the Warranty.
3. Any claim made pursuant to the terms of the Warranty must be made within a reasonable time of the discovery of any potential fault or defect.
4. Acceptance of a claim under this Warranty is subject to an assessment of the Goods by Bromic, or its authorised agent, to determine the cause of the defect prior to Bromic's authorisation for repairs to be carried out.
5. Repairs to the Goods must not have been attempted by any person other than an authorised service agent. Repairs attempted by a non authorised agent will void the warranty.
6. Where Goods are located or are to be located in premises where the induction of service or installation personnel is required, any costs for such induction of service or installation agents to gain access to sites is for the account of the customer and not for Bromic.
7. The requirement for repair or replacement of the Goods must not be due to misuse, neglect, accident, improper installation, unauthorised modification or other abuse which in the reasonable opinion of Bromic was occasioned by the purchaser or any agent or employee of the purchaser.
8. Repair or supply of a substitute will not extend or renew the warranty period.
9. Bromic will warrant that any spare parts it provides will be free from defects and/or faults in materials and/or workmanship for a period of 3 months from the date of purchase provided that these spare parts have been installed by a Bromic authorised service agent.
10. Bromic will either undertake the repair or nominate a repair agent authorised by Bromic.
11. Bromic's repair warranty is restricted to normal business hours on Monday to Friday and excluding public holidays and weekends.
12. Where Bromic elects to replace rather than repair the Goods and no identical replacement is available for the Goods being replaced, Bromic may replace the Goods with Goods of a similar standard and design then available from its range.
13. Bromic is not liable for the costs of the authorised service agents other than standard labour costs during normal working hours.
14. Bromic is not liable for travelling time in excess of 50 kilometres from an authorised service agent or 1 hour from the authorised service agent, whichever is the lesser.
15. Bromic is not responsible for any costs involved in gaining access to Goods for the purposes of repairs, checks or modifications.
16. Bromic's warranty does not extend to any damage or induced Goods' failures resulting from an installation that was undertaken outside the direct control of Bromic or its authorised service/installation agents.
17. Bromic is not liable, and will not authorise repairs pursuant to a claim under this Warranty, for Goods which have been modified for rental purposes. (All Goods are designed to be operated indoors in a permanent location. Movement of goods after installation should be restricted to whatever is required for routine cleaning and maintenance only).
18. Bromic will not be responsible or liable for damage or loss caused during transport and/or testing of the Goods and will not be liable for the cost of transport or testing of the Goods.

19. Bromic does not warrant the Goods where the Goods were installed and/or used in conjunction with goods of a supplier other than Bromic ('the other goods') in such a way as to exceed the capacity and/or performance capabilities of the Goods or the other goods and denies all liability for any damage whatsoever suffered by any person arising from such use.
20. Bromic shall not be liable for any indirect or consequential loss, loss of profit or any other economic loss as a result of any actual or alleged failure of the Goods.
21. The obligation of Bromic in relation to the warranty, provided for in the previous paragraphs, is not valid in the following cases:
 - a. Installation does not conform to the instructions given in the Use and Maintenance handbook;
 - b. Installation in places other than the original place (disassembly and reassembly in another place);
 - c. Carelessness, negligence or inability in use or use other than that for which the product is designed and/or dimensioned; or
 - d. Modifications or tampering with the product.
23. Bromic is not liable for, and will not authorise repairs pursuant to a claim under this Warranty for:
 - a. Breakage of ceramic medium, burner tiles or plastic components of the Goods;
 - b. Replacement of burners, controls or components which have been damaged by exposure to spillage;
 - c. Damage or failure of Goods as a consequence of not removing packaging and transport materials before use;
 - d. Parts subject to wear and tear including but not limited to fuses, batteries, handles, locks, hinges, hoses;
 - e. Goods which have not been installed in accordance with Bromic's and/or the manufacturer's specification;
 - f. Extraordinary and unforeseeable events (voltage surges, irregular electric power supply, natural events and disaster, riots etc);
 - g. Repairs or replacement of Goods not bearing original serial numbers (where applicable) or compliance plate;
 - h. Rust and/or discoloration due to heat or exposure to corrosive environments;
 - i. Damage caused to Goods due to improper use of cleaning agents, detergents, bleaches or other chemical additives or agents of a corrosive nature;
 - j. Breakage, either intentional or unintentional, to any part of the Goods;
 - k. Any damage arising from any modification of the Goods that has taken place without prior authorisation from Bromic;
 - l. Any use of the Goods for any reason other than its originally specified purpose;
 - m. Installation of Goods in places other than the original place (disassembly and reassembly in another place);
 - n. Carelessness, negligence or use other than that for which the Goods are designed;
 - o. Goods not performing correctly as a result of Goods being used in an environment whereby the ambient temperature and relative humidity are outside the operating parameters specified for those particular goods;
 - p. Modifications or tampering with the Goods; or
 - q. Heater Failure of the Goods due to;
 - i. Incorrect installation of gas supply;
 - ii. Insufficient regular maintenance (of the type specified by the relevant manufacturer) of components including but not limited to injectors (every three months & more frequently if required), burners etc.;
 - iii. Insufficient and/or irregular cleaning of the injectors (every three months & more frequently if required);
 - iv. Failure to provide adequate ventilation for the Goods as specified by the manufacturer; or
 - v. Fair wear and tear of the Goods;
24. Please contact Bromic as soon as possible after discovery of a potential defect and/or fault with the Goods to arrange for it to be tested and/or serviced.

25. All warranty enquiries and/or claims should be directed to Bromic's Head Office via its postal address - PO Box 6062 Silverwater NSW 1811 or by telephoning 1300 276 642 (within Australia) or sending a fax to +61 2 9748 4289.
26. The manufacturer is not responsible for assuring compliance with jurisdictional codes and regulations governing sales, construction, installation and/or use of the heating products and cannot be responsible for how the product is installed or used. Before purchase and use of the product, it is the responsibility of the owner to review the product application and all applicable national and local codes and regulations governing the installation and use of such heating products and to seek advice from relevant technical persons.
27. In addition to the above, all of Bromic's other general terms and conditions of trade apply, save for those which are inconsistent with the terms of this warranty. These general terms and conditions of trade can be obtained on request from Bromic.
28. In addition to the Warranty extended by Bromic to the Purchaser, the Australian Consumer Law requires that Bromic provide the following additional guarantees to consumers (as that word is defined by the Competition and Consumer Act) in respect of consumer goods (as defined by that Act) supplied in Australia.

Our goods come with guarantees that cannot be excluded under the Australian Consumer Law. You are entitled to a replacement or refund for a major failure and for compensation for any other reasonably foreseeable loss or damage. You are also entitled to have the goods repaired or replaced if the goods fail to be of acceptable quality and the failure does not amount to a major failure.

For more information visit our website at www.bromicheating.com or call 1300 276 642.

Head Office: PO Box 6062 Silverwater, Sydney, NSW 1811 Australia.

WARRANTY REGISTRATION PROCEDURE

Any claim under this warranty should be initiated with the **dealer/retailer** who sold the Goods, or with any other dealer handling Bromic's products.

To register your product please fill out your the registration form at <http://www.bromicheating.com/warranty>

Please ensure you have the following information during this process;

Serial Number of Heater: _____

Gas Pressure:* __ kPa (Please enter digit(s) and circle the unit of measure)

Gas Type:* LPG or Natural Gas (Please circle applicable fuel source)