

ON/OFF CONTROLS



ON/OFF 1 & 2 CHANNEL



ON/OFF 5 CHANNEL

DESCRIPTION:

The Affinity On/Off series, available in 3 models - single channel, dual channel and five channel, allows for connected Platinum or Tungsten Collection gas or electric Bronic Heaters to be turned on or off at full power capacity – providing straight forward function and usage of your outdoor heater.

The 1 and 2 channel models provide both Bluetooth and Wi-fi communication capabilities using the Bronic App. The 5 channel model includes options for ethernet connectivity or BMS integration via 0-10 VDC built-in. Ethernet and BMS/HAS connectivity can be added to the single channel and dual channel models via an optional expansion board.

The new design allows the controls to be mounted in a variety of convenient locations both indoors and outdoors, within the range of the site's internet connectivity and operates using a smart device with a Bluetooth or Wi-Fi connection.

The Bronic Smart-Heat App is available on the App Store and Google Play Store.

DIMENSIONS:

*Dimensions shown in mm (inches)

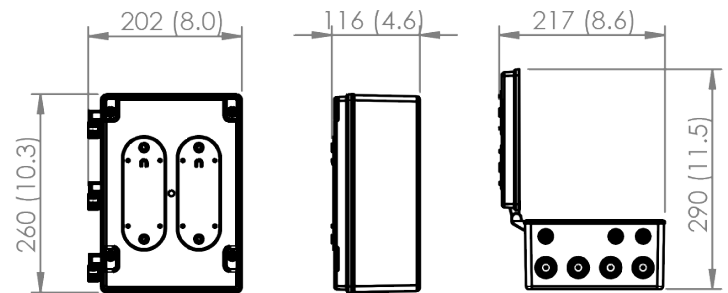

ON/OFF 1 & 2 CHANNEL

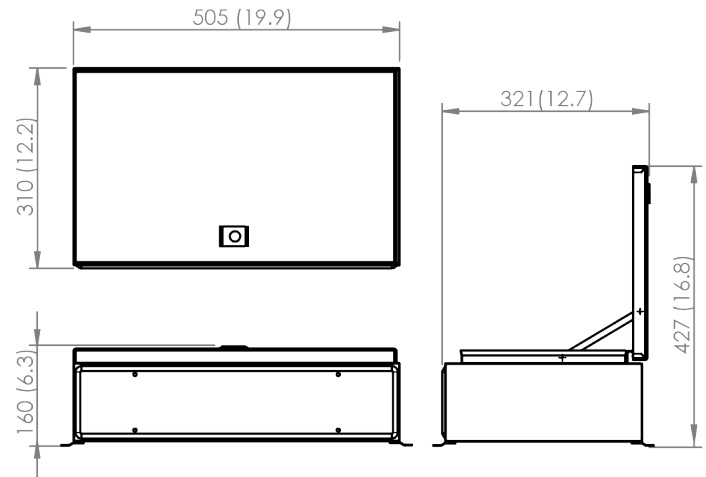

ON/OFF 5 CHANNEL

CLEARANCES

Allow sufficient clearance for cabling.

*Clearances shown in mm (inches)

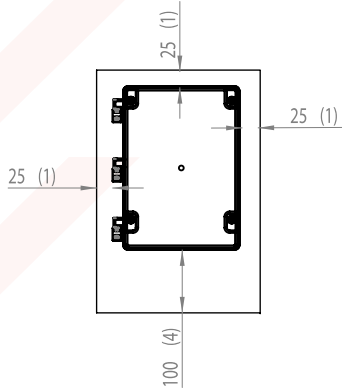

ON/OFF 1 & 2 CHANNEL

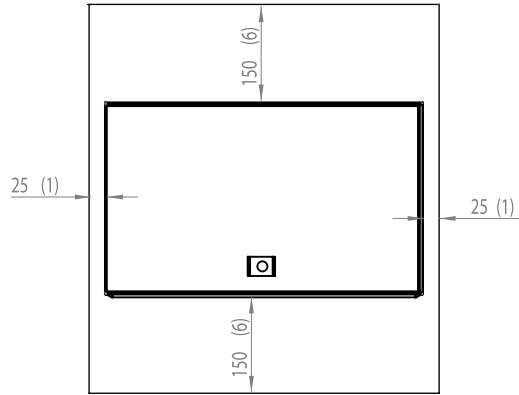

ON/OFF 5 CHANNEL

MOUNTING OPTIONS:

Mounting location should be selected to avoid accidental contact.

Wall Mounting

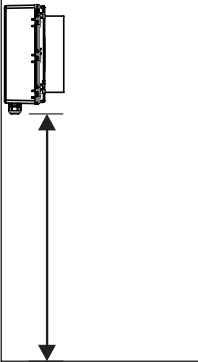

Suitable for all OnOff models.

Ceiling Mounting

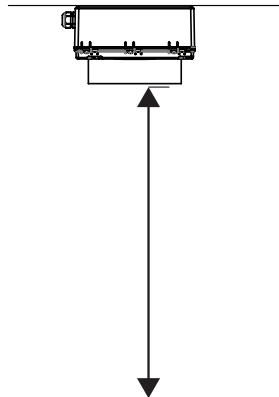

Suitable for only the OnOff Channel 1 & 2 models.



PRODUCT SPECIFICATIONS

| Model | Smart-Heat Control On/Off 1 CH | Smart-Heat Control On/Off 2 CH | Smart-Heat Control On/Off 5 CH |
|------------------------------------|----------------------------------|----------------------------------|--|
| Part Number | BH3130051 | BH3130052 | BH3130053 |
| Number of Channels | 1 | 2 | 5 |
| Voltage - Max Capacity Per Channel | 100-127V - 1kW 220-240V - 6kW | 100-127V - 1kW 220-240V - 6kW | 3N- 220/380V - 6kW 3N- 230/400V - 6kW 3N- 240/415V - 6kW 3N- 277/480V - 6kW |
| Operating Temperature Range | -20°C to +30°C | -20°C to +30°C | -20°C to +30°C |
| Non-Operating Temperature Range | -30°C to +70°C | -30°C to +70°C | -30°C to +70°C |
| Protection Rating | IP54 | IP54 | IP54 |
| Dimensions | 290 x 202 x 112mm | 290 x 202 x 112mm | 500 x 340 x 202mm |
| Weight | 1.4kg | 1.6kg | 11.0 kg |

This equipment complies with EN/IEC 61000-3-II. For more information including mounting requirements, wiring diagrams and controller clearances, please refer to the Installation Manual.

OPTIONAL ACCESSORY

Bromic's Expansion Board accessory option for the 1 and 2 channel On/Off and Dimmer controls, allows for seamless ethernet integration for a full-proof connection to your outdoor heaters managed via the Bromic Heating app. Additional 0-10V connections allow for seamless plug and play to your Home Automation System or Business Management System.

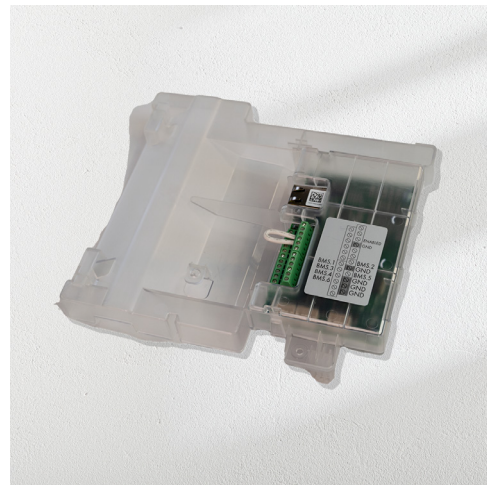

SCAN TO LEARN
MORE ABOUT
OUR CONTROLS



SCAN TO LEARN
MORE ABOUT
OUR APP

BROMIC
HEATING