

PLATINUM SMART-HEAT™
GAS HEATER
BY BROMIC

INSTALLATION, INSTRUCTION AND SERVICE MANUAL

SUITABLE FOR GAS RADIANT HEATER MODELS:
PLATINUM 300 - BURNER AND PLATINUM 500 -

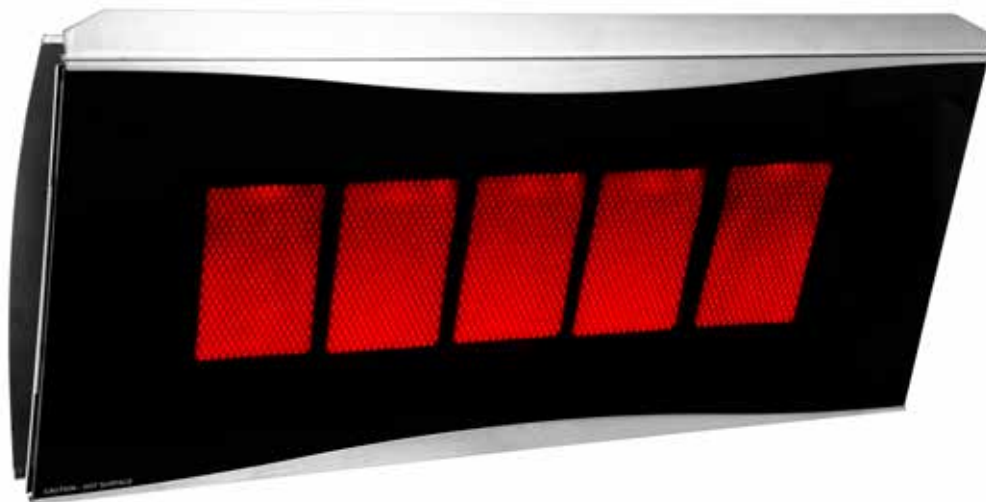

DANGER

If you smell gas:

1. Shut off gas to the appliance
2. Extinguish any open flame
3. If odor continues, keep away from the appliance and immediately call your gas supplier or fire department.



WARNING: For Outdoors Use Only.



WARNING

Do not store or use gasoline or other flammable vapor and liquids in the vicinity of this or any other appliance.



WARNING: Improper installation, adjustment, alteration, service or maintenance can cause property damage, injury or death. Read the installation, operating and maintenance instructions thoroughly before installing or servicing this equipment.

This manual contains important information about the assembly, operation, and maintenance of Platinum Smart-Heat Heaters. Please pay close attention to the important safety information shown throughout this instruction manual. Any safety information will be accompanied by the following safety alert symbols:

 DANGER,  WARNING,  IMPORTANT

- READ THIS MANUAL CAREFULLY before installing or servicing this product.
- Improper installation, operation, or maintenance can result in death, severe injury, or property damage.
- This appliance must be installed in accordance with the rules in force and local regulations. Before installation, check that the local distribution conditions, nature of gas and pressure, and adjustment of the appliance are compatible.
- The heater, when installed, must be electrically grounded in accordance with local codes .
- This appliance is approved FOR OUTDOOR OR AMPLY VENTILATED AREA USE and for NON DOMESTIC INDOOR APPLICATION
- When installed outdoors this appliance MUST be protected from rain.



The ventilation requirements necessary to comply with the installation regulations in the country where the appliance is to be installed. The ventilation must be in accordance with EN 13410.

Note: This manual covers indoor non domestic use and complies with appropriate sections of BS EN 419-1 - Non-domestic gas-fired overhead luminous radiant heaters - Safety

Note: This manual covers Outdoor or Amply Ventilated area of use. It is applicable to domestic (residential) use and complies with appropriate sections of BS EN 14543 - Specification for dedicated liquefied petroleum gas appliances - Parasol Patio Heaters - Flueless radiant heaters for outdoor or amply ventilated area use.

BROMIC[®]
HEATING

Head Office: 10 Phiney Place, Ingleburn, Sydney, NSW 2565 Australia
T: 1300 276 642 (within Australia) or +61 2 9748 3900 (from overseas) **F:** +61 2 9748 4289
E: info@bromic.com **W:** www.bromic.com/heating

Note: Bromic Heating reserves the right to make changes to specifications, parts, components and equipment without prior notification. This Installation, operation and service manual may not be reproduced in any form with prior written consent from Bromic Heating.

CONTENTS

IMPORTANT NOTES & WARNINGS	4
PRODUCT OVERVIEW	5
PRODUCT DESCRIPTION	5
SPECIFICATIONS	6
GENERAL INFORMATION	6
PRODUCT FEATURES	6
INSTALLATION REQUIREMENTS	7
GAS REQUIREMENTS	7
INSTALLATION CLEARANCES	8
INSTALLATION INSTRUCTIONS	9
HEATER INSTALLATION INSTRUCTIONS	9
GAS SUPPLY INSTALLATION	13
POWER SUPPLY INSTALLATION	13
LEAKAGE TEST	13
HEAT DEFLECTOR INSTALLATION INSTRUCTIONS	14
COMMISSIONING INSTRUCTION - CHECK GAS PRESSURE	14
CEILING MOUNT POLE INSTALLATION INSTRUCTIONS	15
OPERATING INSTRUCTIONS	16
TURNING THE APPLIANCE ON	16
TURNING THE APPLIANCE OFF	16
MAINTENANCE AND SERVICING	16
REGULAR SERVICE REQUIREMENTS	16
EXTERIOR SERVICING	16
OPTIMUM MOUNTING DISTANCE	17
HONEYWELL CONTROL	17
HONEYWELL VALVE	18
WIRING DIAGRAM	19
REPLACEMENT PARTS	20
POST-INSTALLATION REPORT	22
TROUBLESHOOTING	23
APPENDIX A	24

IMPORTANT NOTES AND WARNINGS



WARNING

- THIS APPLIANCE SHALL NOT BE INSTALLED OR USED IN RESIDENTIAL DOMESTIC INDOOR AREAS
- CHILDREN AND ADULTS SHOULD BE ALERTED TO THE HAZARDS OF HIGH SURFACE TEMPERATURES AND SHOULD STAY AWAY TO AVOID BURNS OR CLOTHING IGNITION
- YOUNG CHILDREN SHOULD BE CAREFULLY SUPERVISED WHEN THEY ARE IN THE AREA OF THE HEATER
- DO NOT USE OR STORE FLAMMABLE MATERIALS NEAR THIS APPLIANCE
- CLOTHING OR FLAMMABLE MATERIALS SHOULD NOT BE HUNG FROM THE HEATER OR PLACED ON OR NEAR THE HEATER
- DO NOT SPRAY AEROSOLS OR FLAMMABLE MATERIALS IN THE VICINITY OF THIS APPLIANCE WHILE IT IS IN OPERATION
- ANY GUARD OR OTHER PROTECTIVE DEVICE REMOVED FOR SERVICING THE HEATER (CONDUCTED BY AN AUTHORIZED PERSON) MUST BE REPLACED PRIOR TO OPERATING THE HEATER
- INSTALLATION AND REPAIR SHOULD BE DONE BY A QUALIFIED SERVICE PERSON. THE HEATER SHOULD BE INSPECTED BEFORE USE AND AT LEAST ANNUALLY BY A QUALIFIED SERVICE PERSON

Failure to follow the warnings and instructions in this manual could result in severe personal injury, death or property damage.

- This Installation, Operation and Service manual should not be removed from the site of installation.
- Installer should leave manual with the customer for future reference.
- This Appliance is approved FOR OUTDOOR OR AMPLY VENTILATED AREA USE. (see attached diagrammatical representations of outdoor areas "Appendix A") and for NON DOMESTIC INDOOR APPLICATION.
- Do not perform maintenance until heater has been turned off, power disconnected, and heater temperature has cooled to room temperature.
- Do not expose the burner to water or moisture. THE APPLIANCE IS TO BE PROTECTED FROM RAIN.
- Do not use the heater if any of these parts are exposed to water until the appliance is inspected or repaired by an authorised service person.
- The installer is to ensure that the requirements of the local authority, local gas fitting regulations, municipal building codes, and any other relevant statutory regulations are carried out.
- Certain materials or items, when stored under or near the appliance, will be subjected to radiant heat and could be seriously damaged. Ensure combustible materials eg. overhead structures, walls, floors, furniture, fixtures and plants must be kept 1100mm from the top and side.
- The whole gas system, hose assembly, regulator, pipes, and burner should be inspected for damage and leaks before use and at least annually by an authorized person for the life of the heater.
- All leak tests should be done with a soap solution. Never use an open flame to check for leaks.
- Do not use the heater until all connections have been leak tested by an authorised person.
- Inspect the hose assembly before each use of the appliance.
- The hose assembly must be replaced prior to the appliance

being put into operation if there is evidence of excessive abrasion or wear, or if the hose is damaged.

- The replacement hose assembly must be AGA approved.
- The hose assembly is not to be located in areas where the hose may be subject to accidental damage.
- This radiant heater is NOT intended to be installed on recreational vehicles and/or boats.
- Repair to be carried out ONLY by an authorised person.
- Improper installation, adjustment, or alteration can cause personal injury, property damage, or even death.
- Do not attempt to alter the unit in any manner.
- Remove transit protection before use.
- Never operate the heater in an explosive environment such as areas where petrol or other flammable liquids or vapours are stored.
- Turn off the gas supply immediately if smell of gas is detected.
- Do not paint any surface of the heater.
- Do not throw objects at Glass facia.
- The facia breaks, discontinue use, disconnect power and gas and isolate area affected by breakage.
- Control compartment, burner and circulation air passageways of the heater must be kept clean. Frequent cleaning may be required as necessary.
- Turn Gas Supply off when not in use.
- Check the heater immediately if any of the following occurs:
 - » The heater does not reach temperature.
 - » The burner makes popping noise during use (a slight noise is normal when the burner is ignited or extinguished).
- This appliance can be used by children aged from 8 years and above and persons with reduced physical, sensory or mental capabilities or lack of experience and knowledge if they have been given supervision or instruction concerning use of the appliance in a safe way and understand the hazards involved. Children shall not play with the appliance. Cleaning and user maintenance shall not made by children without supervision.
- Check for damage to the appliance regularly. If damage to the cord, plug or appliance is suspected, discontinue use immediately and contact the supplier or qualified person for repair.
- If the supply cord and plug is damaged, It must be replaced by the manufacturer, its service agent or similarly qualified persons in order to avoid hazard.
- Avoid inhaling fumes emitted from the heater's first use. Smoke and odour from the burning of oils used in manufacturing will appear. Both the smoke and odour will dissipate after approximately 30 minutes.
- Ensure that a watertight seal is maintained on the electrical control box at all times
- Regularly check for damage to the rubber seals. If damage to the rubber seals is suspected, discontinue use immediately, switch off power and contact the place of purchase or authorized service technician for repair.
- The heater is not located immediately below a socket outlet
- The appliance shall, under no circumstances, be covered with insulating material or similar material.
- Fire Sprinklers must be located at an appropriate distance from each heater to avoid accidental activation of the sprinkler. Ethylene glycol or propylene glycol must never be used in fire sprinkler systems where heaters are present as these substances maybe become flammable when heated. A fire sprinkler professional must be consulted when heaters are installed where fire sprinklers are present to ensure that heaters and the fire sprinkler system are properly integrated.

PRODUCT OVERVIEW

SPECIFICATIONS (Table 1)

Platinum Smart-Heat 300									
Gas type	G31 PROPANE ¹			G20 NATURAL GAS ²		G25 NATURAL GAS ²	G20 NATURAL GAS ²	G30 BUTANE ³	
Gas Category	I _{3P} (30)	I _{3P} (37)	I _{3P} (50)	I _{2H} (20)	I _{2E} (20)	I _{2L} (25)	I _{2E+} (20/25) ³	I _{3B/P} (30)	I _{3B/P} (50)
Injector Size	0.82	0.82	0.82	1.20	1.20	1.20	1.10	0.77	0.77
Country	FI, NL & RO	BE, CH, CZ, IT, ES, FR, GR, GB, HR, LT, NL, PT, SK, IE, SI & PL	AT, CH, DE, NL, LU & SK	AT, BG, CZ, DK, EE, FI, GR, HR, HU, IS, IE, IT, LV, LT, NO, PT, RO, SK, SI, ES, SE, CH, TR & GB	DE, LU, & PL	NL	BE & FR	BE, CY, DK, EE, FI, FR, HU, IT, LT, NL, NO, SE, SI, SK, RO, HR, TR, BG, IS, LU, MT & LV	AT, CH, DE & SK
Number of Injectors	3								
Gas Connection Size	Rp ½	Rp ½ EXCEPT - France - Belgium - Denmark	Rp ½ EXCEPT G1/2 - France - Belgium - Denmark	Rp ½ EXCEPT G1/2 - France - Belgium - Denmark	Rp ½	Rp ½	G1/2	Rp ½ EXCEPT G1/2 - France - Belgium - Denmark	Rp ½ EXCEPT G1/2 - France - Belgium - Denmark
Norminal Pressure mbar	30	37	50	20	20	25	20	30	50
Minimum Pressure mbar	25	25	42.5	17	17	20	17	25	42.5
Maximum Pressure mbar	35	45	57.5	25	25	30	25	35	57.5
Burner Pressure mbar	25	25	25	15	15	20	19	25	25
Heat Input (Gross)	7.0kW - 500g/hr								
Weight	12.5kg								
Voltage	220 - 240V								

1. Propane gas appliance shall be used on a regulated supply and not to be connected directly by hose and regulator to a cylinder
2. Natural gas appliance shall be used on a regulated supply
3. Governor out of action
4. Not designed for field conversion.

Platinum Smart-Heat 500									
Gas type	G31 PROPANE ¹			G20 NATURAL GAS ²		G25 NATURAL GAS ²	G20 NATURAL GAS ²	G30 BUTANE ³	
Gas Category	I _{3P} (30)	I _{3P} (37)	I _{3P} (50)	I _{2H} (20)	I _{2E} (20)	I _{2L} (25)	I _{2E+} (20/25) ³	I _{3B/P} (30)	I _{3B/P} (50)
Injector Size	0.82	0.82	0.82	1.20	1.20	1.20	1.10	0.77	0.77
Country	FI, NL & RO	BE, CH, CZ, IT, ES, FR, GR, GB, HR, LT, NL, PT, SK, IE, SI & PL	AT, CH, DE, NL, LU & SK	AT, BG, CZ, DK, EE, FI, GR, HR, HU, IS, IE, IT, LV, LT, NO, PT, RO, SK, SI, ES, SE, CH, TR & GB	DE, LU, & PL	NL	BE & FR	BE, CY, DK, EE, FI, FR, HU, IT, LT, NL, NO, SE, SI, SK, RO, HR, TR, BG, IS, LU, MT & LV	AT, CH, DE & SK
Number of Injectors	5								
Gas Connection Size	Rp ½	Rp ½ EXCEPT G1/2 - France - Belgium - Denmark	Rp ½ EXCEPT G1/2 - France - Belgium - Denmark	Rp ½ EXCEPT G1/2 - France - Belgium - Denmark	Rp ½	Rp ½	G1/2	Rp ½ EXCEPT G1/2 - France - Belgium - Denmark	Rp ½ EXCEPT G1/2 - France - Belgium - Denmark
Norminal Pressure mbar	30	37	50	20	20	25	20	30	50
Minimum Pressure mbar	25	25	42.5	17	17	20	17	25	42.5
Maximum Pressure mbar	35	45	57.5	25	25	30	25	35	57.5
Burner Pressure mbar	25	25	25	15	15	20	19	25	25
Heat Input (Gross)	11.7kW - 840g/hr								
Weight	16.5kg								
Voltage	220 - 240V								

1. Propane gas appliance shall be used on a regulated supply and not to be connected directly by hose and regulator to a cylinder
2. Natural gas appliance shall be used on a regulated supply
3. Governor out of action
4. Not designed for field conversion.

PRODUCT DESCRIPTION

The Platinum Smart-Heat Series Gas Radiant Heaters are designed to provide effective heating.

The heaters incorporate full function electronic controls, allowing them to be operated remotely from a conveniently located

switch. The heaters have been designed to withstand the rigors of the outdoors.

NOTE: The Platinum heaters are designed only for wall mounting or ceiling pole mounting

PLATINUM SMART-HEAT HEATER DIMENSIONAL DETAILS

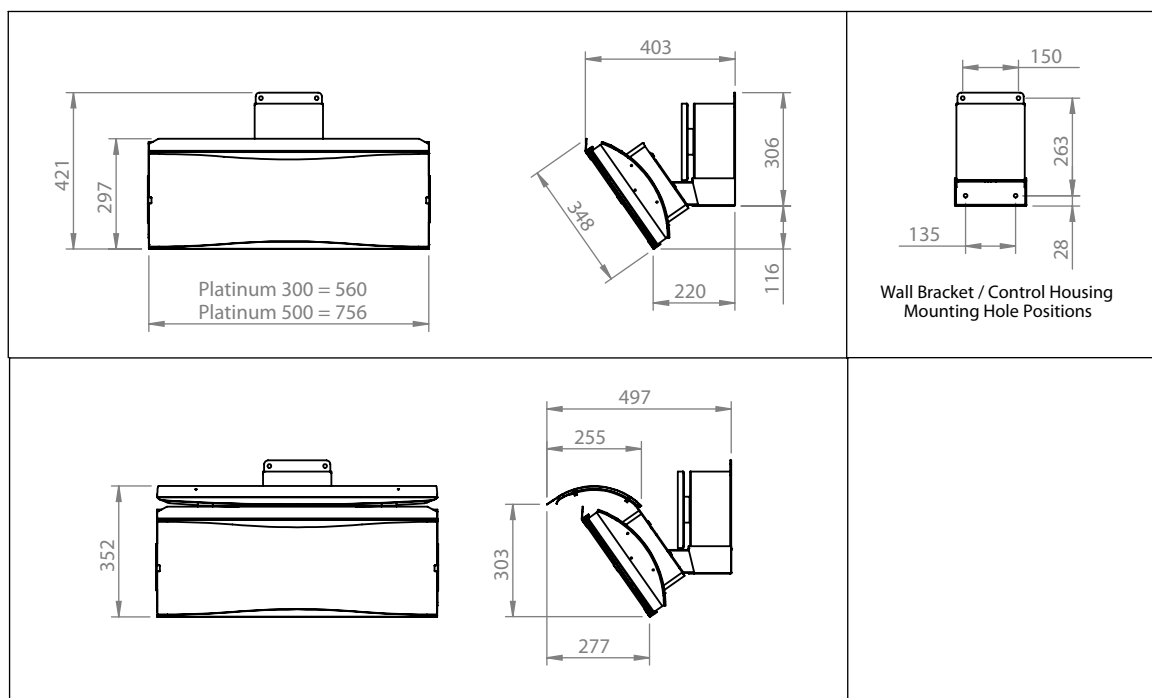

IMPORTANT

This appliance is approved for outdoor or amply ventilated area use and for NON DOMESTIC INDOOR APPLICATIONS, and must be installed by authorised persons. For commissioning of the appliance see page 8. This appliance is to be protected from rain. Install under a protective cover.

This appliance must be installed in accordance with the rules in force. Before installation, check that the local distribution conditions, nature of gas and pressure, and adjustment of the appliance are compatible.

GENERAL INFORMATION

The Platinum Series Gas radiant heaters are suitable for outdoor or amply ventilated areas and non domestic indoor use. In addition to the installation instructions provided, authorised installers must abide by the local gas installation code. Please note that these standards are subject to change.

The heater is designed to function in winds up to 15Km/h. The heater is subject to reduced performance or failure in adverse weather conditions such as high wind or extreme saturation.

WARNING

- Do not expose the burner to water or moisture. THE APPLIANCE IS TO BE PROTECTED FROM RAIN.
- Do not use the heater if any of these parts are exposed to water until the appliance is inspected or repaired by an authorized service person.

PRODUCT FEATURES

- An amply ventilated area must have a minimum of 25% of the surface area open.
- The surface area is the sum of the walls surface. An amply ventilated area must have a minimum of 25% of the surface area open. The surface area is the sum of the walls surface.

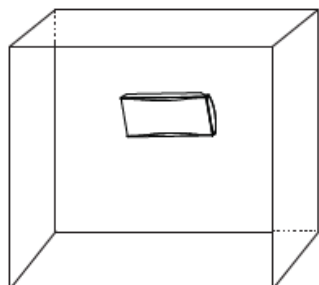

“The tubing or the flexible hose must be changed within the prescribed intervals”;

“Use only the type of gas and the type of cylinder specified by the manufacturer”;

This appliance must be installed and the gas cylinder stored in accordance with the regulations in force.

IMPORTANT

This appliance shall only be used in above ground open-air situations with:

- natural ventilation
- without stagnant areas
- where gas leakage and products of combustion are rapidly dispersed by wind and natural convection

Any enclosure in which the appliance is used shall comply with one of the following:

1. 25% of surface area is open. The surface area is the sum of the wall surface (ref. Appendix A, Example 1)
2. Within a partial enclosure that includes an overhead cover and no more than two walls (ref. Appendix A, Example 2)
3. Within a partial enclosure that includes an overhead cover and more than two walls, the following shall apply:
 - At least 25% of the total wall area is completely open (ref. Appendix A, Example 4), and
 - At least 30% of the remaining wall area is open and unrestricted (ref. Appendix A, Example 4)

Note: The definition of outdoors is an above ground openair situation with natural ventilation, without stagnant areas, where gas leakage and products of combustion are rapidly dispersed by wind and natural convection.

GAS REQUIREMENTS

Platinum Smart-Heat LPG Models:

- Use Propane (LPG) gas only
- The approved inlet pressure to the appliance

Platinum Smart-Heat Natural Gas Models:

- Use Natural Gas Only
- The approved inlet pressure to the appliance

INSTALLATION REQUIREMENTS CONTINUED...

INSTALLATION CLEARANCES

When selecting the installation location for the Platinum Smart-Heat Heaters, the following mounting clearances should be followed.

Care should be taken to ensure that the heater is not installed:

- Where heat/ignition can cause damage to gas cylinders/lines
- Near other combustible materials
- In open locations subject to rain
- In indoor residential locations
- In areas without sufficient clearances (refer below)

Note: When Installing with No protective cover, the

Note: Heater should be installed in such a way so as to allow adequate;

- Clearance around air openings to combustion chamber
- Clearance from combustible material

following installation clearances shall apply:

Note: When installing with the Platinum Smart-Heat

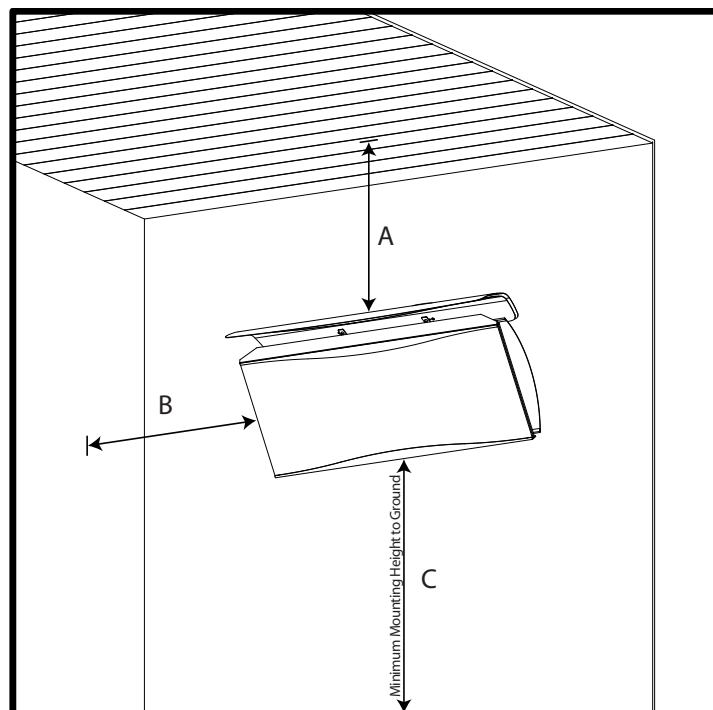
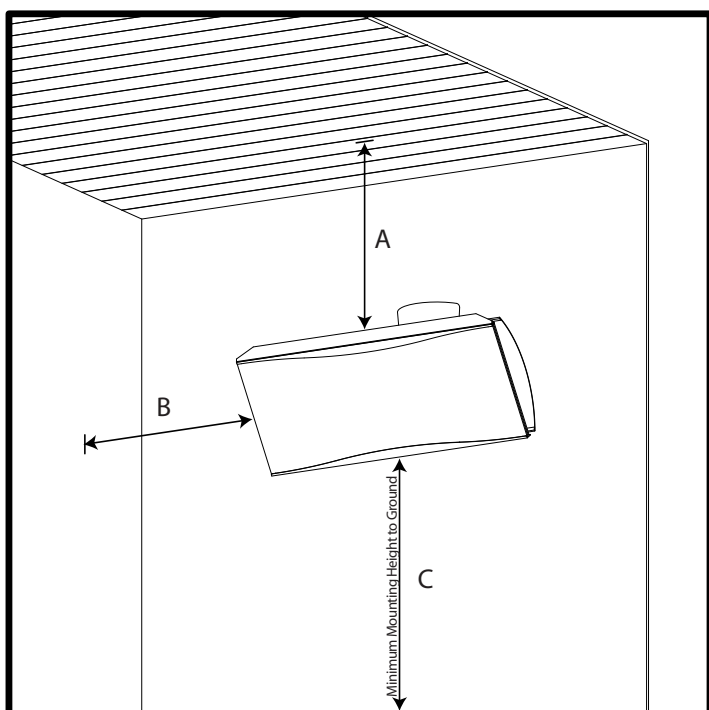

Minimum height to combustible materials			
Model	A	B	C
300 Series	1100mm	1100mm	2500mm*
500 Series	1100mm	1100mm	2500mm*

*Bromic recommended minimum installation height. Local authority regulations and building codes must be checked prior to installation

Minimum height to combustible materials			
Model	A	B	C
300 Series	350mm	1100mm	2500mm*
500 Series	350mm	1100mm	2500mm*

*Bromic recommended minimum installation height. Local authority regulations and building codes must be checked prior to installation

! IMPORTANT

For Non Domestic Indoor Application. The Ventilation must be in accordance with EN 13410

! IMPORTANT

This appliance must only be used in a well ventilated area.

Note: Minimum room size (EN13410:2001) The installation room shall have a volume of at least 10m³/kW of installed nominal heat input of the radiant heaters.

! IMPORTANT

Minimum room volume requirements must be confirmed with local authorities.

INSTALLATION INSTRUCTIONS

WARNING

This appliance must be installed and used in accordance with local Gas installation standard and must meet all the requirements stipulated in the "Installation Requirements" section of this manual. Before installation, check that the location distribution conditions, nature of gas and pressure and adjustment of the appliance are compatible.

WARNING:

Installation should be done by a qualified service person.

CAUTION

Please see specifications for the weight of the Heater. The installer of the Platinum Smart-Heat Series Radiant Heaters must comply with all relevant State Occupational Health & Safety Regulations.

HEATER INSTALLATION INSTRUCTIONS

1. Mount Wall Bracket/Control Housing To Wall:

- Remove Wall Bracket/Control Housing From Packaging
- Place the mounting bracket in position and mark the fixing hole location on the wall. Drill holes using appropriate drill size and type.

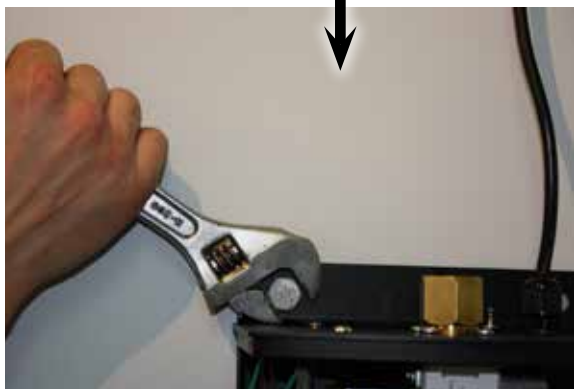
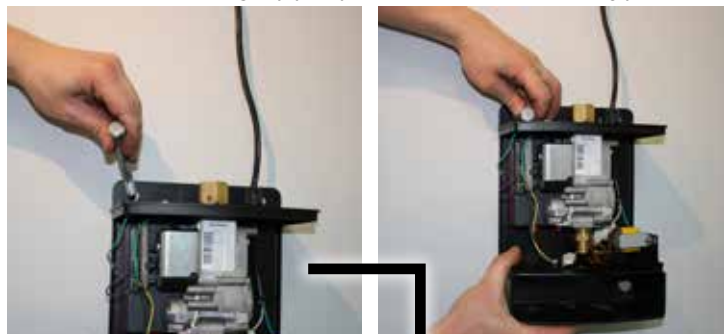

IMPORTANT

The Heater shall be firmly and securely attached to the wall. **For Brick and masonry**, use M8 "Flush Head" "Dynabolts" (or equivalent). **For Wood / Timber fixtures**, use suitable screw fixings no less than 60mm in length.

WARNING

When mounting wall bracket/ control housing, ensure the anchoring to the structure is of sufficient strength, quality and workmanship to support the weight of the heater and any other load that could be applied to the fixture.

- Attach the bracket to the wall using appropriate fixtures
2. Connect AGA approved Flexible Gas Connector (as supplied) to the inlet fitting on the heater using 2 wrenches to tighten. Leak Test by applying compressed air (1/2" PSI) to open end of flexible hose. Spray gas fittings with a soapy water solution and Check for leaks. Alternatively, leak check can be done after assembly using inspection

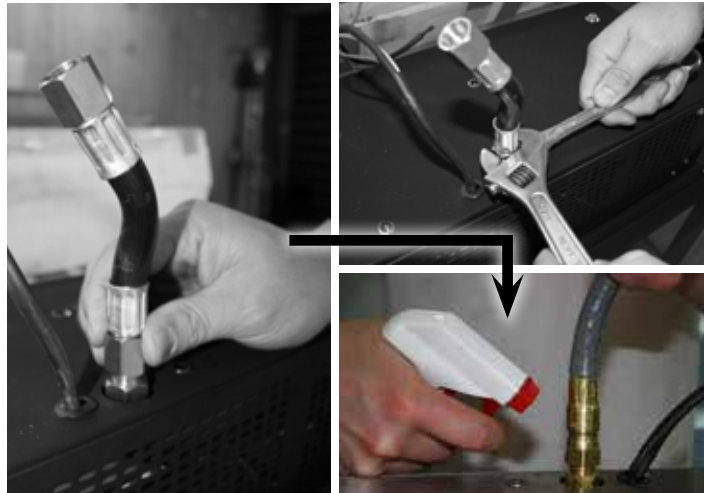

hole on bracket arm. (see. leakage test section of this manual).

3. Fix Mounting Arm to the back of the heater -

- Slide Gas Connector and Wiring Harness inside the centre of the arm and have them exit through the shaped cut-out on top surface of the arm
- Ensure that the arm faces downwards at a 55° angle
- Position the 4 mounting holes on the arms plate over the corresponding fixtures on the heater - Manipulate the gas hose as necessary to allow for correct alignment
- Insert and tighten 4 M6 bolts as provided to fit mounting arm to heater.



INSTALLATION INSTRUCTIONS CONTINUED...

4. Attach Heater to Wall Bracket/Control Housing

- Remove Front Cover from Control Housing
- Attach Heater to Wall Bracket/Control Housing by inserting Mounting Arm into lower channel of Wall Bracket. Ensure that the Gas Hose and Wiring Harness slide through the groove on top side of the control Housings lower channel and remain undamaged by the metals edges during assembly.
- It may be necessary to manipulate the gas Hose so that the arm can slide into place.

TIP: Do not install the mounting pin at this point.

- Spray soapy water on the arm to ease the sliding.

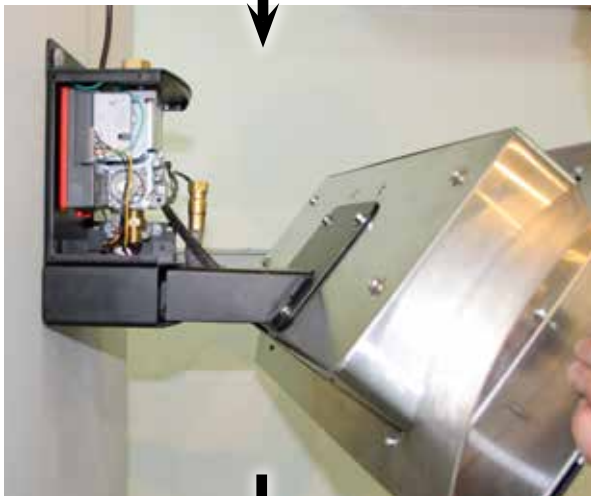

5. Connect an approved flexible connector to the Gas Valve Outlet Fitting

- Position heater and hose so that the gas hose and fitting are in alignment
- **NOTE:** ensure that the hose nut and valve fitting are parallel to one another and threads are engaged correctly before tightening! Incorrect installation can cause gas leaks and damage components.

TIP: Sliding the mounting arm inside the control housing's channel can help accurately Position the Gas hose in place under the gas valve's fitting.

- Spanner Tighten using 2 wrenches, and leak test using soapy water (see section "leakage test")

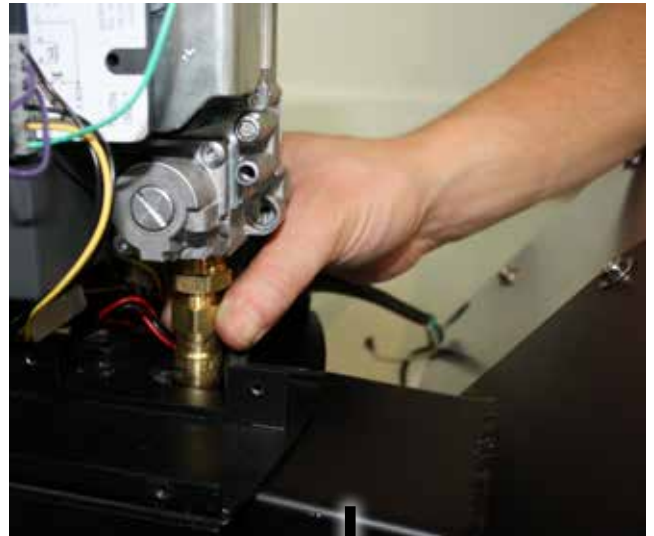

For Honeywell Control

6. Insert Pivot Bolt

- Position Arm so that the rear hole's on the mounting arm and Control Housing are in alignment
- Insert Bolt and washer (as supplied) through Control Housing and Mount Arm, using the hole located on the bottom surface of the Control Housing, towards the rear. Spanner tighten in place
- Select desired heater angle and insert the M6 Bolt and washer (as supplied) through the bottom surface of Control Housing into the



! IMPORTANT

Electrical connections must be completed by trained and authorized electrical technicians only!

mounting arm, using the corresponding hole. (Heaters angle will be 0°, 10° or 20°). Spanner tighten in place

7. Connect the 3 wires from the heater by carefully following the instructions below

PLEASE NOTE: THERE IS NO NEED TO REMOVE OR UNPLUG THE CONTROL MODULE FROM THE GAS VALVE OR WALL BRACKET ASSEMBLY

- Using a pair of needle nose pliers, grip the white ionisation terminal as shown, being mindful of the terminal pins of the control module.

Ignition (smaller terminal)



Ionisation (larger terminal)



- Insert the ionisation terminal into the terminal pin furthest away.
- Ensure that the terminal firmly clicks into place.



- Repeat the process with the black ignition cable inserting the terminal into the closer, smaller terminal pin.



- Insert Plug the green earth terminal into one of the available spade terminals attached to the top of the wall bracket.



8. Connect gas inlet fitting to mains gas supply in accordance with local gas installation code and gas supply installation section of manual. Leak test with soapy water

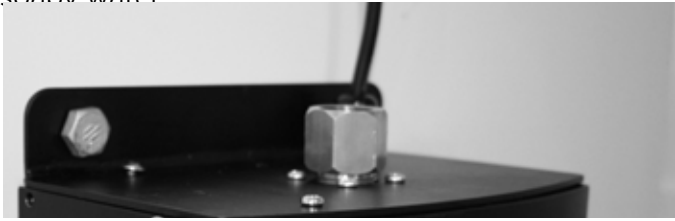

9. Fix Front cover to control housing using the 4xM4 screws provided. Front cover must be assembled with 4x supplied screws for IPX4 rating.



10. Main Power supply connection is to be completed in line with instructions in the "Power supply installation" section of this manual.

! IMPORTANT

Ensure that a water tight seal is maintained.

! IMPORTANT

After gas installation and electrical installation is complete, all gas lines should be tested for leaks using a soapy water solution. See Section titled "Leakage Test" for further information. Ensure gas pressure meets the requirements outlined in Gas Supply Installation above.

! IMPORTANT

Children of less than 3 years should be kept away unless continuously supervised.

Children aged from 3 years and less than 8 shall only switch on/off the appliance provided that it has been placed or installed in its intended normal operating position and they have been given supervision or instruction concerning use of the appliance in a safe way and understand the hazards involved. Children aged from 3 years and less than 8 years shall not plug in, regulate and clean the appliance or perform user maintenance.

CAUTION - Some parts of this product can become very hot and causes burns. Particular attention has to be given where children and vulnerable people are

GAS SUPPLY INSTALLATION

Before installing, check that the local distribution conditions, nature of gas and pressure and adjustment of the appliance are compatible. Where multiple appliances are installed and supplied from a common gas supply it is important to check that the gas supply pipe is adequately sized for the number of appliances fitted.

! IMPORTANT

- **All gas supply installation work must be performed by trained and authorized person(s) and comply with the requirements of local Gas Installation Codes.**
- **All Piping Joints should be tested for leaks with a soapy water solution before use.**
- **Gas hose must be located out of pathway where people may trip over it, or in areas where the hose**

Verify the type of gas supply complies with the appliance rating plate, located at the back of the heater.

An approved manual isolating valve must be fitted before the heater in accordance with local Gas



Tighten all the connections and then turn on the gas supply. Check for gas leakage with a soapy water solution. (See section titled "Leakage Test").

Do not use an open naked flame to check for leaks.

! IMPORTANT

When the heater is operating, check gas pressure at the test point and ensure the manifold pressure to the heater is: as per table 1 on page 5.

Gas supply pressure must be limited to if gas line pressure exceeds this level, a separate pressure reducing regulator must be installed.

The appliance and its individual shutoff valve must be disconnected from the gas supply piping system during any pressure testing of that system at test pressures in excess of 35mbar.

The appliance must be isolated from the gas supply piping system by closing its individual manual shutoff valve during any pressure testing of the gas supply piping system at test pressures equal to or less than 35mbar.

POWER SUPPLY INSTALLATION

! WARNING

This heater is equipped with a three-prong (grounding) plug for your protection against shock hazard and should be plugged directly into a properly grounded three-prong receptacle. Do not cut or remove the grounding prong from this plug.

The Platinum Smart-Heat Gas Heater comes standard with 900mm of power cord in addition to the Approved 3 pin power plug.

If an appropriate power socket is available, the heater can be plugged into this power socket and operated using the on/off switch supplied on the power socket. Alternatively, the power installation can be tailored to suit the site requirements by an Authorized Electrician.

Keep electrical supply cord away from any heated surface and flue gasses.

Please Note:

Platinum Smart-Heat Gas do not have their own on/off switch. Operation should be controlled via the main power supply.

! WARNING

Ensure that power socket is switched off before plugging in power cord.

LEAKAGE TEST

Gas connections on the heater are leak tested at the factory prior to shipment. A complete gas tightness check must be performed at the installation site due to possible mishandling in shipment or excessive pressure being applied to the heater. Check ALL connections.

- The heater must be checked with the gas supply turned on.
- Make sure the safety control valve is in the OFF position.
- Make a soap solution of one part liquid detergent and one part water. The soap solution can be applied with a spray bottle, brush or rag. Soap bubbles will appear in case of a leak.
- Turn the gas supply ON.
- In case of a leak, turn off the gas supply. Tighten any leaking fittings, then turn the gas supply on and recheck.
- Never leak test while smoking.

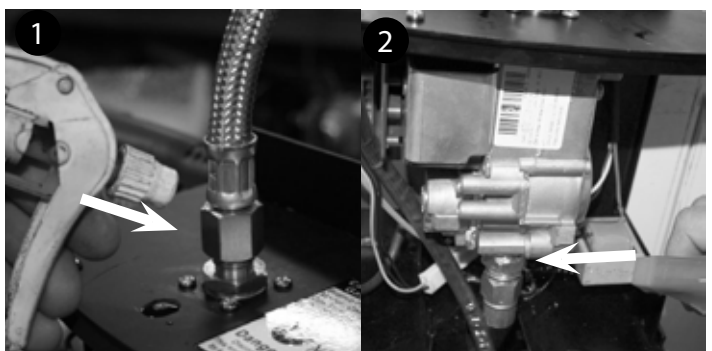

LEAKAGE TEST - CONTINUED

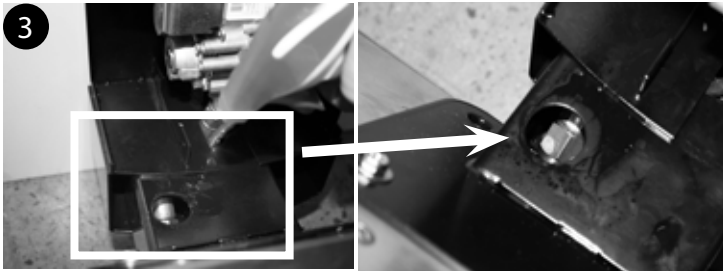

HEAT-DEFLECTOR INSTALLATION

1. Assemble Heat Deflector following instructions supplied in the Heat Deflector carton.
2. Mount Heat Deflector to back of heater by loosening the two screws and secure brackets underneath washers. Re-tighten screws to original position using screw driver.

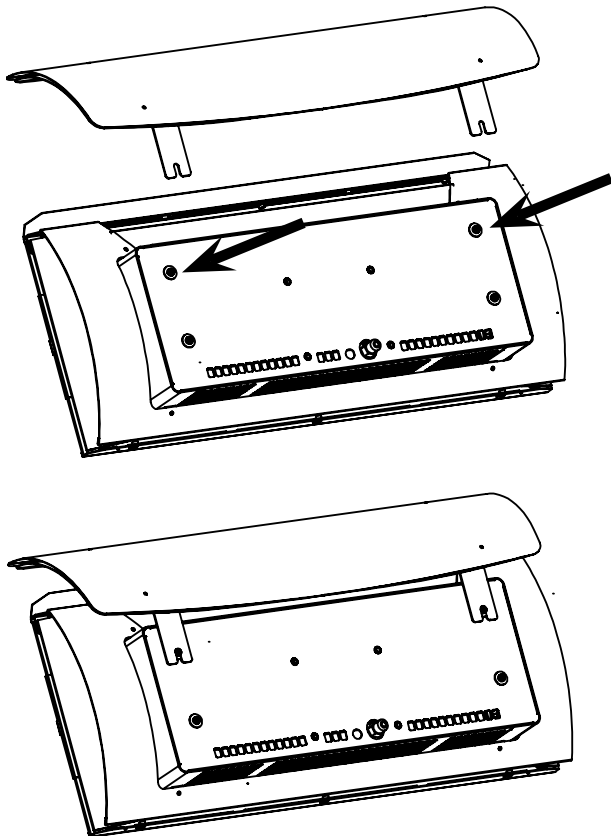

COMMISSIONING INSTRUCTION

(CARRY OUT LEAKAGE TEST IF NOT ALREADY DONE)

CHECK GAS PRESSURE



WARNING

IMPROPER INSTALLATION AND ALTERATION CAN CAUSE INJURY AND PROPERTY DAMAGES. READ THE INSTALLATION AND OPERATING MANUAL THOROUGHLY BEFORE INSTALLING THE HEATER.



- Inlet pressure test point
- Burner pressure test point
- Regulator cap

A) Check inlet pressure

Unscrew the inlet pressure test point sealing screw (one to two turns) on the Honeywell multifunctional control and connect a manometer. (see photograph A above). **Turn on the appliance and check that the inlet pressure is as indicated as in the specifications table 1 on page 5.** Switch off the appliance, remove the manometer tube from the control valve and screw in the sealing screw.

B) Check the burner pressure

Unscrew the burner pressure test point sealing screw (one to two turns) on the Honeywell multifunctional control and connect a manometer (see photograph B1). Turn on the appliance and operate for at least 5 minutes. Check that the burner pressure is as indicated as in the specification table on page 5.

If the burner pressure is incorrect unscrew the regulator cap (see photograph B2) from the Honeywell multifunctional control and adjust the burner pressure by turning the pressure regulator adjustment screw (using a suitable screwdriver) clockwise to increase and anti-clockwise to decrease the burner setting pressure (see photograph B3).

On obtaining the correct burner pressure, switch off the appliance, remove the manometer tube and screw in the sealing screw.

C) Replace Regulator Cap

Replace the regulator cap and seal by applying red paint to prevent unorthorised adjustment. Place regulator cover cap back on regulator. Place plug screw back into the outlet plug. Ensure screws are tightened.



CEILING POLE INSTALLATION

WARNING

When mounting ceiling pole, ensure the anchoring to the structure is of sufficient strength, quality and workmanship to support the weight of the heater and any other load that could be applied to the fixture. Note: Ceiling pole must be perpendicular (90deg) to the ground when mounted (irrespective of pitched or flat ceiling).

1. Mount Top Bracket to ceiling or support beam using suitable fixings no less than 60mm length.
2. Assemble pole to the mounting bracket using the M8x100mm and M19x100mm bolts, and fix using nuts and washers (as supplied).
3. Assemble both lower paddles to the pole (back to back) and insert 3 M10x100mm bolts and fix using nuts and washers (as supplied).
4. Fix Heater to Lower paddles using suitable fixtures.

NOTE: Platinum Smart-Heat Heating recommends running power and gas lines, to the heater, inside the pole to reduce visibility and likelihood of damage.

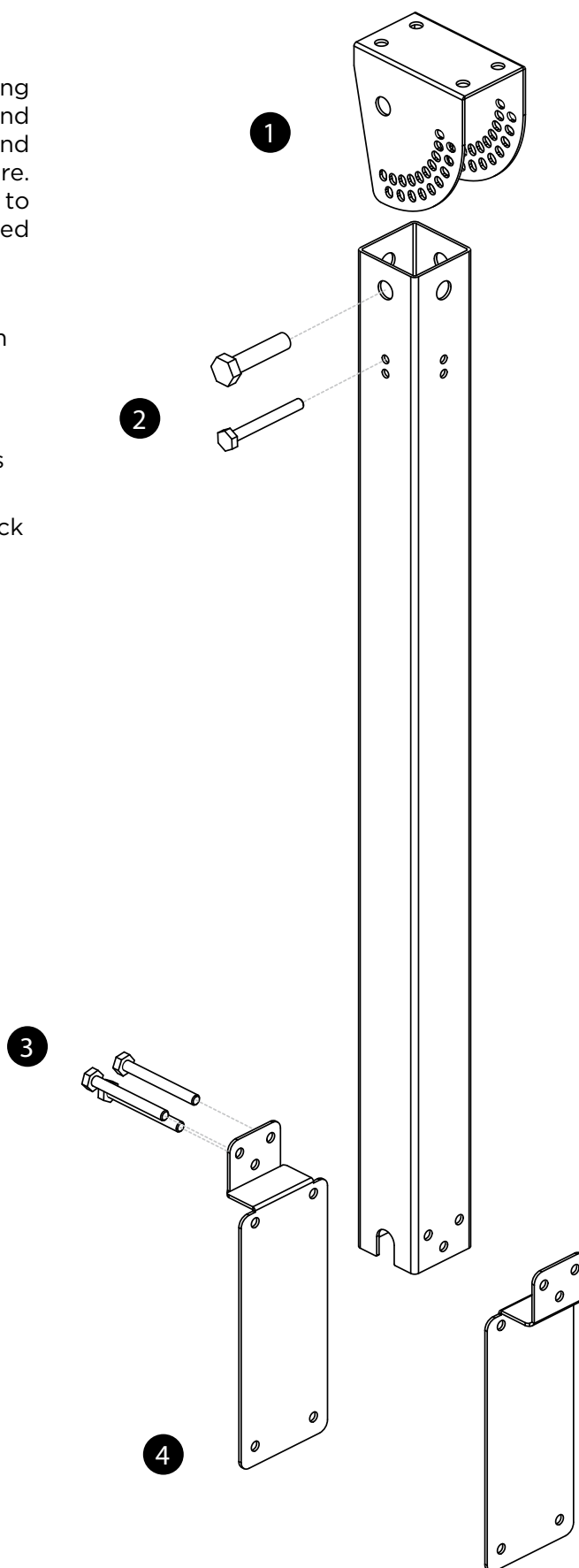

OPERATING INSTRUCTIONS

TURNING THE APPLIANCE ON

1. Ensure that gas installation and power installation has been carried out in accordance with the manufacturers instructions outlined in this document.
2. Turn on gas supply.
3. Ensure correct gas supply pressures are set.
4. Switch on power to heater.
5. If Gas heater does not light, turn power off.
6. Wait 5 seconds before turning power back on. If heater does not ignite after 5 attempts, consult the troubleshooting section of this manual, or contact Platinum Smart-Heat Heating Pty. Ltd for service information.

TURNING THE APPLIANCE OFF

1. For temporary shutdown, turn off power.
2. For permanent shutdown, turn off power and shut off gas supply.

NOTE: The appliance must be completely shutoff for a period of 5 minutes before being relighted.

IMPORTANT

Check the heater immediately if any of the following occurs:

- The heater does not reach temperature.
- The burner makes popping noise during use (a slight noise is normal when the burner is ignited or extinguished).

Note: Avoid inhaling fumes emitted from the heater's first use. Smoke and odour from the burning of oils used in manufacturing will appear. Both the smoke and odour will dissipate after approximately 30 minutes.

Installers please Note:

When the installation and testing is completed, make sure that the customer knows how to operate the heater. Leave the operating instructions with the customer.

MAINTENANCE AND SERVICING

It is important that regular maintenance is carried out on the heater to maintain efficient operation. All maintenance should be carried out ONLY by authorized service personnel.

Control compartment, burner and circulation air passageways of the heater must be kept clean. Inspect and clean at least every six months or more frequently in adverse conditions.

Never obstruct the flow of combustion and ventilation air. Always keep the appliance area clear and free from combustible materials, gasoline and other flammable vapors and liquids.

Do not clean heater with cleaners that are combustible or corrosive.

REGULAR SERVICE REQUIREMENTS

1. AGA approved Gas Hose, located within the mounting arm, must be checked at least once annually. The hose must be replaced if there is any evidence of excessive wear, or if the hose is damaged. The replacement hose assembly must be AGA approved with 3/8"SAE flared ends. To Check the Gas Hose, remove control housing cover by removing 8 screws and slide cover outwards. Alternatively, disassemble heater by reversing the installation instructions as outlined in Installation section of this handbook.
2. **VISUALLY CHECK BURNER FLAMES.** During heaters function visually check that all burners are alight and glowing hot. This can be done by observing the red glow through the translucent face, or by peering down the product combustion passageway. Note: A slight variation in colour is to be expected.

1. **Clean burners:** Burners can be cleaned by directing compressed air (max20PSI) at outlet ports. Avoid directing air at gasket material between ceramic tile and burner cup.
2. **Clean manifold and injectors:** Undo gas hose from gas valve outlet (heater should be switched off) and inject compressed air (max20PSI) down the inlet fittings.
3. **Clean dust and foreign matter from inside of heater housing:** Open up rear housing and clear dust using compressed air (max20PSI) and a damp cloth.
4. Remove debris, spider and insect nests from, control compartment, burner and circulation air passageways of the heater with heavy-duty pipe cleaner or compressed air to keep appliance clean and safe for use. Never clear ports or other openings with toothpicks or other articles that will break and block the ports.
5. In a salt-air environment, such as near an ocean, corrosion occurs more quickly than normal. Check frequently for corroded areas and repair them promptly.

IMPORTANT

More frequent cleaning may be required as necessary. It is imperative that control compartment, burners and circulating air passageways of the heater be kept clean.

After service, this appliance is to be re-commissioned as per the commissioning instructions (refer to page 13)

Contact Bromic or Bromc distributor before replacing parts others than those specified on page 22

EXTERIOR SERVICING

The exterior Platinum Smart-Heat Series Heater components are constructed from stainless steel, and high temperature coated black paint. For all exterior black parts (excluding fascia trims), a brushed finish has been used. This is not a coating and under prolonged use, may slightly discolour from high temperatures emitted by the heater. This is a normal occurrence and does not affect the operation of the appliance.

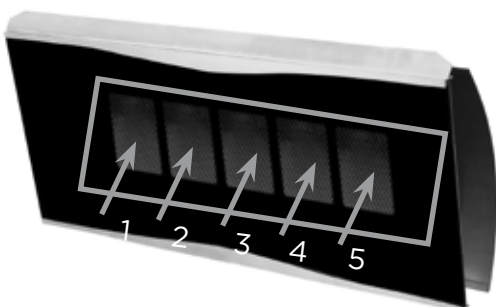

Replacement parts can be purchased to restore the heater to its original appearance from Platinum Heating Pty Ltd. (Refer to parts list in manual).

⚠ IMPORTANT

Do not apply any additional surface coating to the heater under any circumstances. Use of additional coating other than those applied during manufacture could result in hazardous reactions such as toxic fumes or fires. Additional coatings will void the warranty.

OPTIMUM MOUNTING DISTANCE

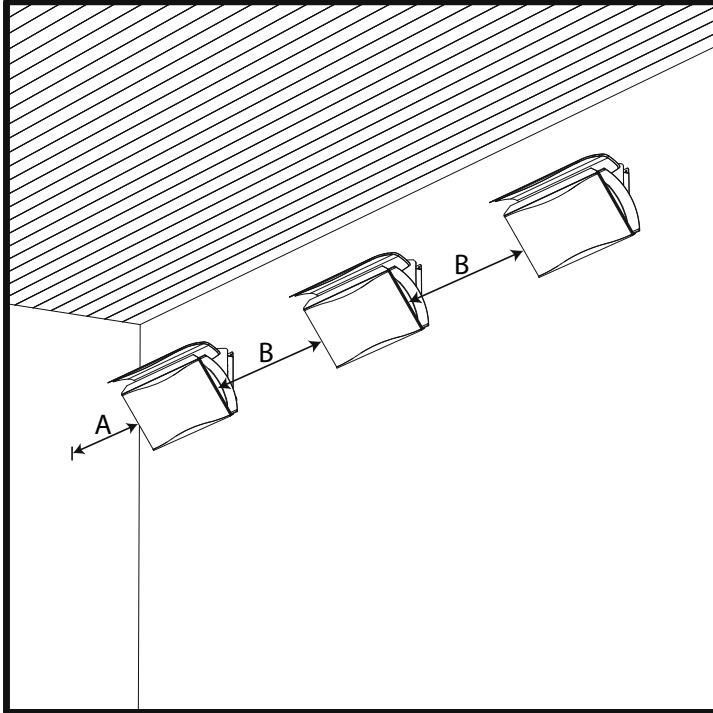

Model	A	B
3 - Burner	1100mm	2500 - 3500mm
5 - Burner	1100mm	2500 - 3500mm

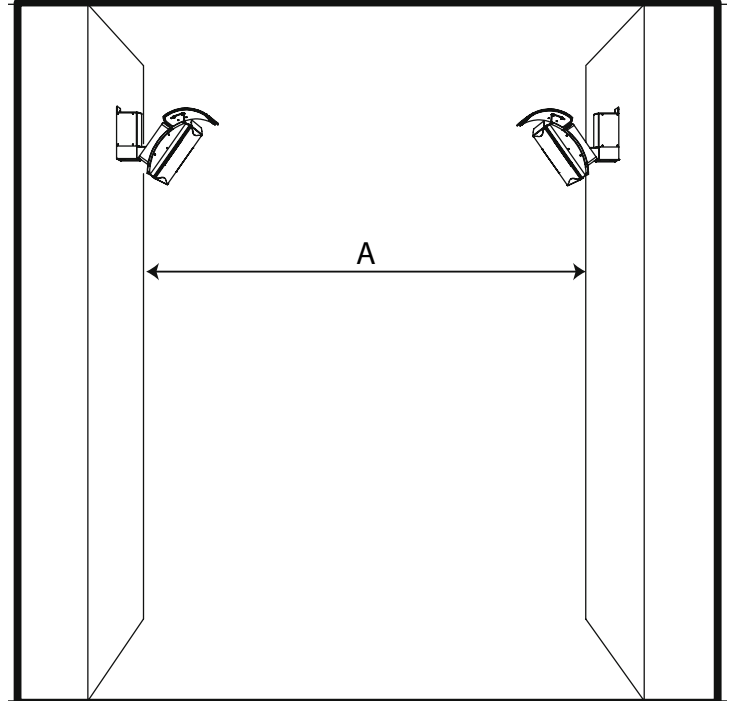

Model	A
3 - Burner	6000 - 7000mm
5 - Burner	8000 - 9000mm

OPERATION DATA - HONEYWELL CONTROL BOX

The following operation sequence is valid only where the components are installed according to the manufactures assembly and installation instructions. Please do not modify the wiring configuration, gas train or any other part of the heater assembly.

Application

The Honeywell electronic gas burner control system is suitable for atmospheric gas burners for non-permanent operation. Although the Honeywell unit is available non volatile lockout, its configuration in the Platinum Smart-Heat series heaters limits it to volatile lockout, i.e. the restart from this condition is possible by the interruption and subsequent restoration of the mains power supply.

Features:

- Compliance with AGA standard for automatic gas burner flame monitoring and control systems
- Compliance with EN 298 (European standard for automatic gas burner flame monitoring and control systems)
- Compliance with AGA (Australian standard for automatic gas burner flame monitoring and control systems)

TECHNICAL DATA

Supply voltage	230V-50/60Hz
Operating temperature	-20°C +60°C
Ambient humidity	90%max at 40°C
Protection degree	IPX4
Timings:	
Self Check time	1.5 s
Safety time (TS)	25 s
Drop out time on running flame failure	1 s
Power consumption, at start up	10W
Power Consumption, Running	4W
Ignition	
Ignition Voltage	15kV with 40pF load
Spark repetition rate	33 Hz
Max. Cable length	1M
Recommended spark gap	0.14"
Consumption	2,5 W

OPERATION DATA - HONEYWELL CONTROL BOX CONTINUED...

Directions for use

- Automatic controls are safety devices and shall not be opened. The manufacturer's responsibility and guarantee are invalid if the control is unduly opened.
- A regulation shutdown must occur every 24hours to enable the unit to check its own efficiency (systems for non permanent operation)
- Connect and disconnect the unit only after switching off the power supply
- Avoid exposing the unit to dripping water
- Ventilation and the lowest temperature ensures the longest life of the control

Electrical Installation

- Live and Neutral should be connected correctly; a mistake could cause a dangerous situation.
- Before starting the system check cables carefully for incorrect installation
- The earth terminal of the control, the metal frame of the burner and the earth on the mains supply must be well connected

Operation

At every start, the control unit proceeds to a self-checking of its own components. During the pre-purge or waiting time (TW) the internal circuit makes a test of the flame signal amplifier. Extraneous light or fault in the amplifier will result in the simulation of a flame which will prevent the control from starting.

At the end of the waiting or pre-purge time, the gas valve is energised and the ignition device is operated. In this way, the safety time (TS) begins.

If a flame is detected during the safety time, the ignition device is inhibited and the gas valve remains energised.

If the control does not detect any flame signal during the safety time, at the end of safety time (TS), the unit proceeds to lockout and the gas valve and ignition device are switched off.

If the established flame signal is lost, (during the safety time or during operation thereafter) this will cause the ignition device to be reactivated within 1 second.

If the burner does not light within 25 seconds of ignition reactivation, the heater will enter failure lockout mode

RESET HONEYWELL CONTROL LOCK-OUT PROCEDURES:

The control ignition can be reset by interrupting the main source. Following procedure to reset the control.

- Turn OFF the main switch and wait for 5 sec.
- Turn ON the main switch and wait for 5 sec.
- The unit has been reset.

OPERATION DATA HONEYWELL VALVE:

The VK series gas control have been specially developed for application in domestic appliances. The Honeywell Gas Valve is a multi-functional control which incorporates an adjustable direct acting pressure regulator. It is designed for operation on 220/240V.

Standard Specifications

- 3/8" SAE Male Thread connection
- Ambient Temperature Range of 0°C to 60°C
- Compact Size: 86.5mm x 63.5mm x 65.9mm
- 50mb Pressure Rating
- 3/8" x 3/8" SAE Inlet and Outlet
- Earthing terminal - 6mm spade tab
- Tamper resistant screws
- Top mounted coils that can be field replaced

TECHNICAL DATA	
Max inlet working pressure	50 mbar
Installation group	Group 2
Operating Temperature	0°C to 60°C
Voltage Ratings	220/240VAC 50/60Hz .52A

ELECTRICAL DIAGRAM

SEE INSTRUCTION MANUAL FOR DETAILS ON HOW TO CONNECT THE ELECTRICAL COMPONENTS.

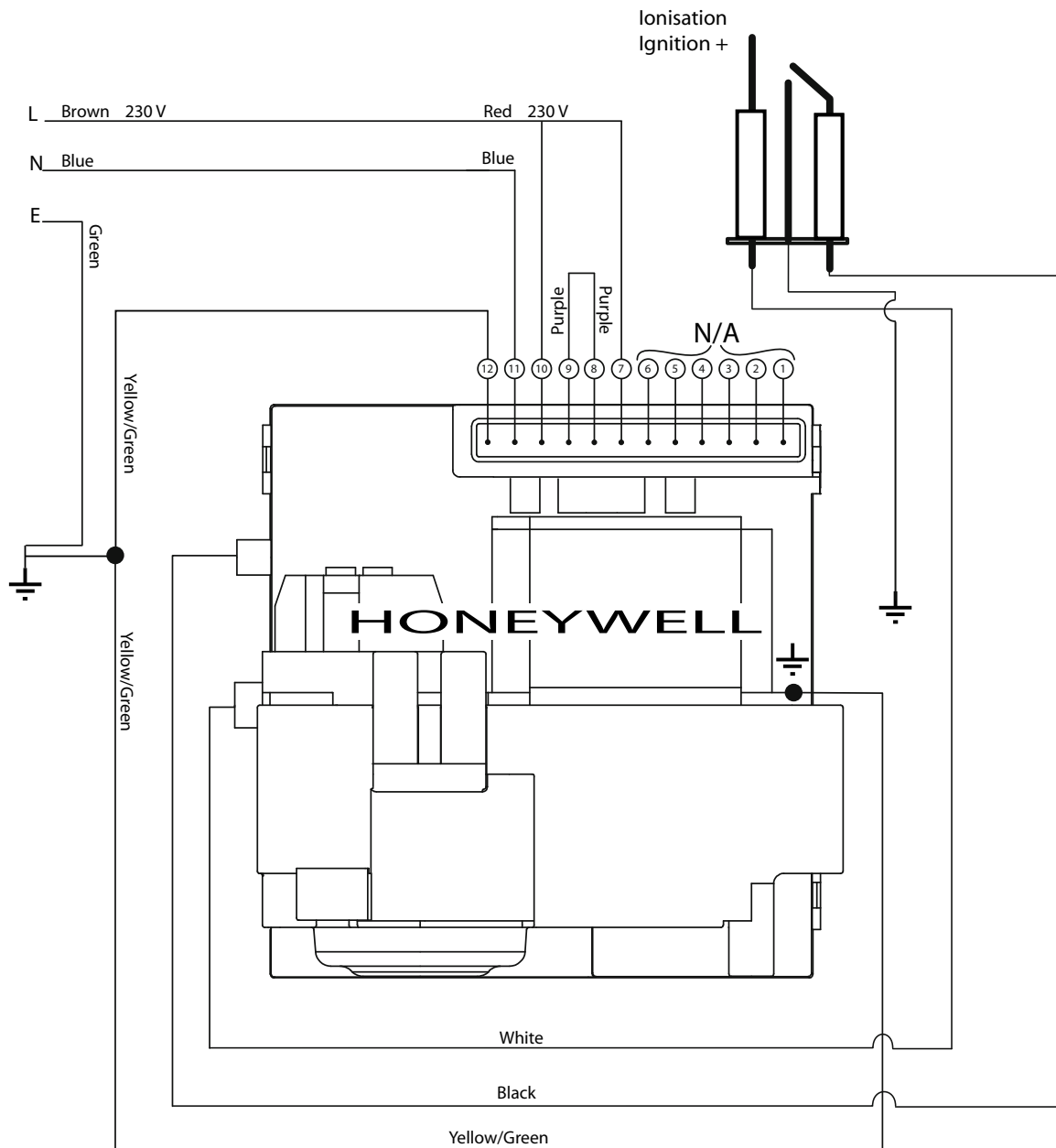

Note:

If any of the original wire as supplied with the heater must be replaced, it must be replaced with 18AWG, 90°C type UL approved wire or its equivalent. If Transformer must be replaced, a UL approved model of similar type must be used.

REPLACEMENT PARTS

Honeywell

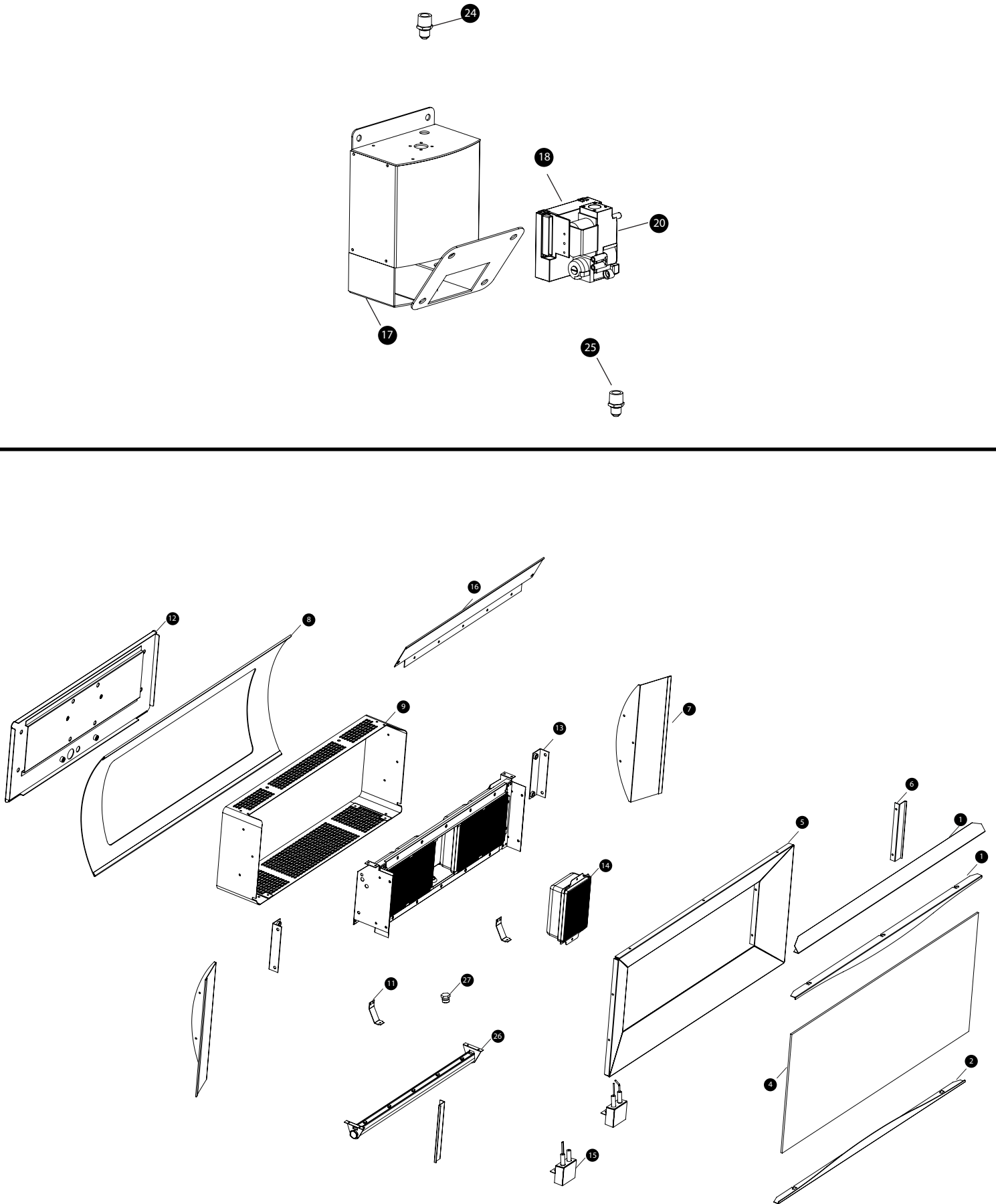

REPLACEMENT PARTS DISCRPTION

No.	Description	Part No. 300 Series	Part No. 500 Series
1	Glass Retainer - Top	BH8080002-1	2620802
2	Glass Retainer - Bottom	BH8080002-1	2620804
3			
4	Glass	BH8080008	BH8080008
5	Reflector Assembly	BH8080018	BH8080019
6	Glass Retainer Side	BH8080020	BH8080020
7	Side Shield	BH8080021	BH8080021
8	Sail	BH8080022	BH8080023
9	Rear Housing	BH8080024	BH8080025
10	Rear Housing Mount (Top)		
11	Rear Housing Mount (Bottom)		
12	Rear Cover Assembly	BH8080026	BH8080027
13	Rear Cover Mount		
14	Burner	BH8080030	BH8080030
15	Wiring Harness + Ignitor Assembly	BH8080010	BH8080011
16	Inner Skin	BH8080028	BH8080029
17	Wall Bracket Assembly		
18	Honeywell Control	BH8080059-1	BH8080059-1
20	Honeywell Valve	BH8080058-1	BH8080058-1
21	19mm ID Grommet	BH8080033	BH8080033
22	8mm ID Grommet	BH8080034	BH8080034
24	Gas Inlet Fitting (Valve)		
25	Gas Outlet Fitting Assembly + Testpoint (valve)		
26	Manifold Assembly		
27	Injector (LPG)		
	Injector (NG)		
	Wall Bracket Replacement Screw Set		
	Heater Replacement Screw Set		

POST-INSTALLATION REPORT

POST-INSTALLATION REPORT FOR PLATINUM GAS RADIANT HEATERS

AFTER HEATER INSTALLATION PLEASE PHOTOCOPY, COMPLETE, & SEND THIS REPORT BY:

Customer Business Name:

Date: **dd** / **mm** / **yyyy**

Site Address:

Suburb:

State: Postcode:

Customer Contact Details:

Name:

Position:

Ph: () Fax: ()

Mobile:

Installer Contact Details:

Name:

Position:

Ph: () Fax: ()

Mobile:

Please fill in the relevant information or circle the appropriate Yes/No responses below:

How many Platinum heaters are installed on this site?	3-Tile: _____	5-Tile: _____
What type of gas is used?	LPG	Natural Gas
Is/Are the heater(s) exposed to salt air or any other corrosive or chemical atmosphere?	Yes	No
Does the heater(s)' installation location pose a hazard to the site?	Yes	No
Do heater clearances match the minimum requirements outlined in the "Installation Requirements" section of the Installation, Operation and Service Manual ?	Yes	No
Is the gas supply line adequately sized for the number of heaters installed?	Yes	No
Have gas lines been purged of air?	Yes	No
Have gas lines been checked for leaks with a soapy water solution?	Yes	No
Was the heater field tested and operated without malfunction?	Yes	No
What is the inlet gas supply pressure?	_____ kPa	
What is the gas valve outlet pressure (at test point)?	_____ kPa	

Signature of authorised person:

Name:

Company: Position:

Date: **dd** / **mm** / **yyyy**

TROUBLESHOOTING

SYMPTOM	POSSIBLE CAUSE	CORRECTIVE ACTION
Heater will not turn on	<ol style="list-style-type: none"> No power No gas 	<ol style="list-style-type: none"> Have authorised electrician check power supply Have authorised gas fitter check gas supply
Heater turns on, but then cycles on and off	<ol style="list-style-type: none"> Insufficient flame on ionisation rod Drafty conditions Insufficient earth connection between heater and control box 	<ol style="list-style-type: none"> <ul style="list-style-type: none"> Check and set gas pressure Check and clear obstruction to burner venturi and injectors Discontinue use in high winds Replace wiring harness and clean connections to ensure good earth
No gas	<ol style="list-style-type: none"> Air in gas line Manual shut-off valve closed Regulator sticking Regulator reversed 	<ol style="list-style-type: none"> Purge line Open valve Replace regulator Remove and install properly
Low ceramic tile surface temperature	<ol style="list-style-type: none"> Low manifold gas pressure Low gas inlet pressure Orifice partially blocked with foreign matter Combustion by-products not adequately ventilated Manifold misaligned from excessive torque applied on pipe at installation Gas supply piping too small Foreign matter in venturi tube 	<ol style="list-style-type: none"> Adjust valve regulator until 1kpa for natural gas, or 2.75kpa for propane is obtained Adjust main supply regulator until at least 1.25kpa for natural gas or 3kpa for propane precedes heater's control assembly Clean orifice Provide adequate ventilation of by-products Replace manifold Increase gas pressure or replace piping Remove with bottle brush
Gas odour	<ol style="list-style-type: none"> Loose pipe connection Defective regulator Defective manual shut-off valve Defective gas control valve Loose flexible hose 	<ol style="list-style-type: none"> Check all connections with soap solution and tighten where necessary Replace regulator Replace manual shut-off valve Replace gas control valve Tighten flexible hose
Burning of gas/air mixture inside burner casting (flashback)	<ol style="list-style-type: none"> Separation of ceramic tiles Ceramic tile(s) cracked Heater mounted at incorrect angle Excessive drafts 	<ol style="list-style-type: none"> Replace burner assembly Replace burner assembly Check angle of heater. See heater nameplate. Shield or relocate heater.
Control assembly is overheating	<ol style="list-style-type: none"> Heater not mounted correctly 	<ol style="list-style-type: none"> Mount wall bracket / control housing against a vertical flat surface, following the instructions outlined in the installation section of this manual. Always use supplied parts to mount heater.

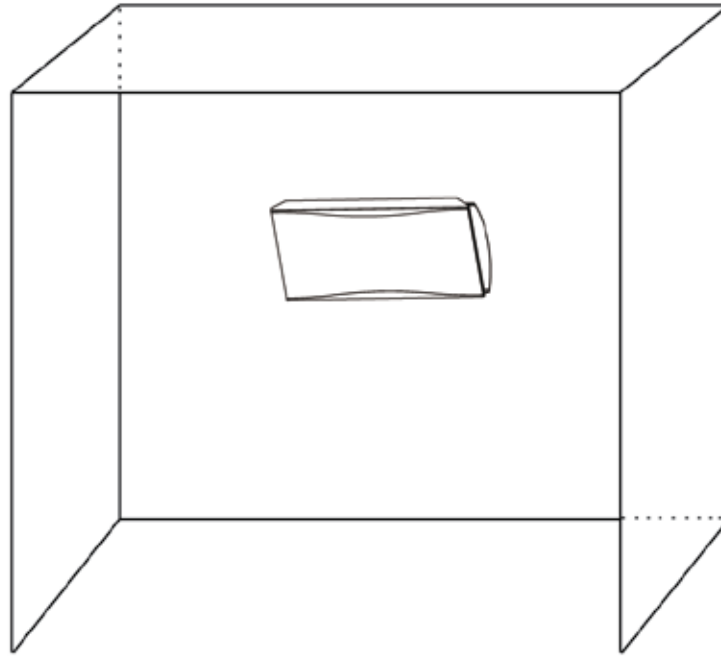

OUTDOOR AREA-EXAMPLE 1

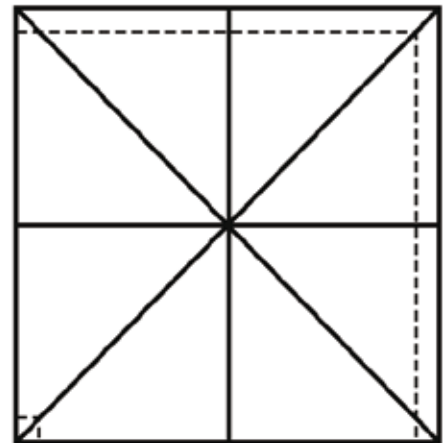
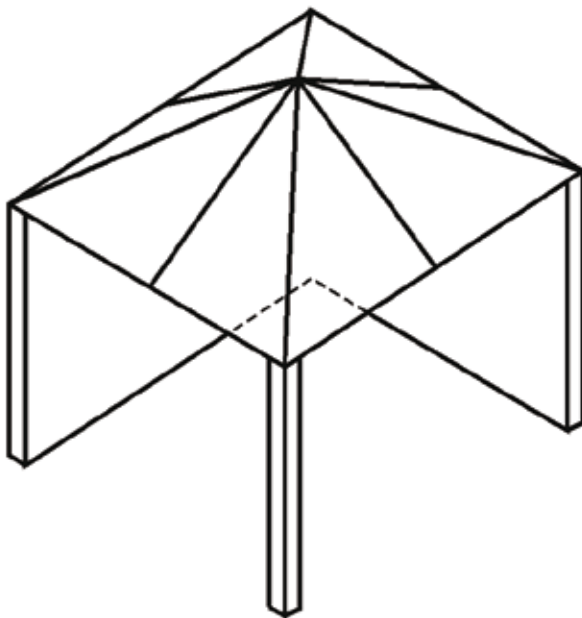

OUTDOOR AREA-EXAMPLE 2

Note: For clearance from combustible materials see page 7

Both ends open

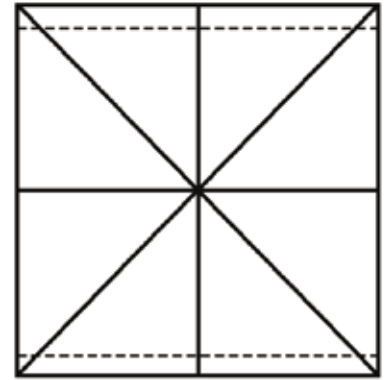
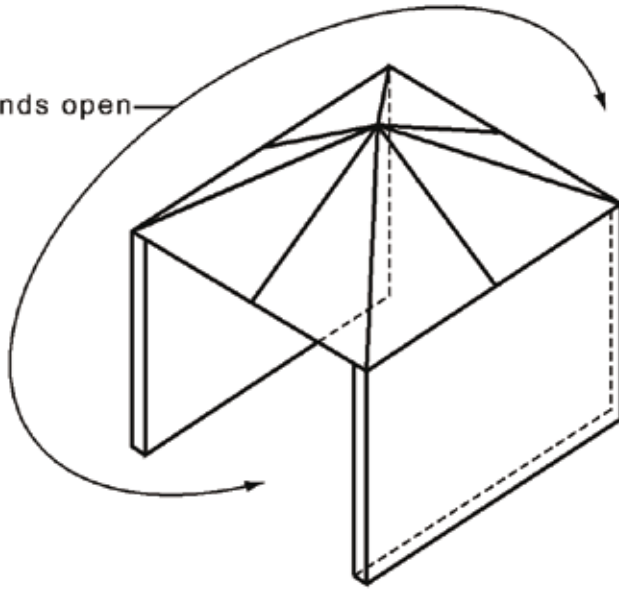

OUTDOOR AREA-EXAMPLE 3

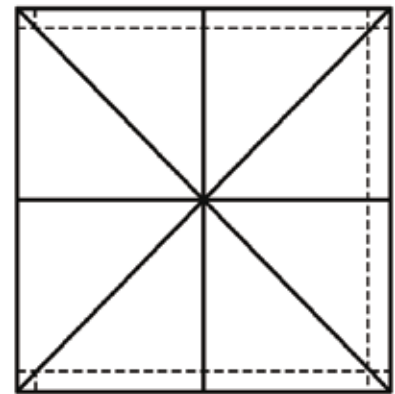
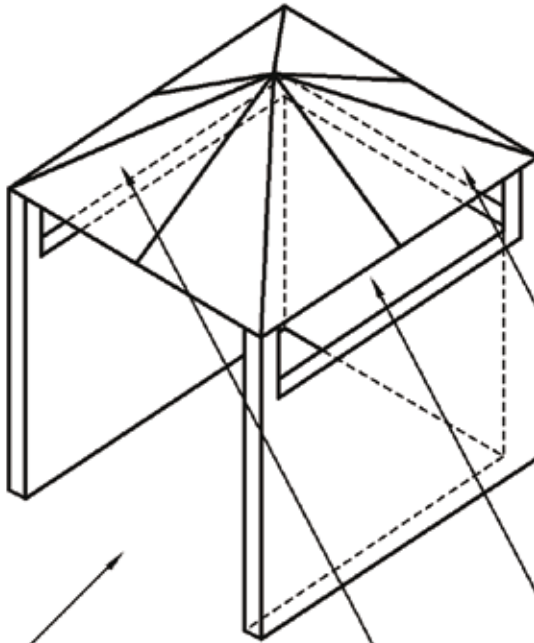

Open side at least 25% of total wall area

30 percent or more in total of the remaining wall area is open and unrestricted

OUTDOOR AREA-EXAMPLE 4

APPENDIX A CONTINUED...

S/N	Abbreviation	Country
1	AT	AUSTRIA
2	BE	BELGIUM
3	BG	BULGARIA
4	CH	SWITZERLAND
5	CY	CYPRUS
6	CZ	CZECH REPUBLIC
7	DE	GERMANY
8	DK	DENMARK
9	EE	ESTONIA
10	ES	SPAIN
11	FI	FINLAND
12	FR	FRANCE
13	GB	GREAT BRITAIN
14	GR	GREECE
15	HR	CROATIA
16	HU	HUNGARY
17	IE	IRELAND
18	IS	ICELAND
19	IT	ITALY
20	LT	LITHUANIA
21	LU	LUXEMBOURG
22	LV	LATVIA
23	MT	MALTA
24	NL	NETHERLANDS
25	NO	NORWAY
26	PL	POLAND
27	PT	PORTUGAL
28	RO	ROMANIA
29	SE	SWEDEN
30	SI	SLOVENIA
31	SK	SLOVAKIA
32	TR	TURKEY