

---

## PLATINUM SMART-HEAT™ GAS HEATER BY BROMIC

## INSTALLATION, INSTRUCTION AND SERVICE MANUAL

**SUITABLE FOR GAS RADIANT HEATER MODELS:  
PLATINUM 300 - BURNER AND PLATINUM 500 - BURNER**

---

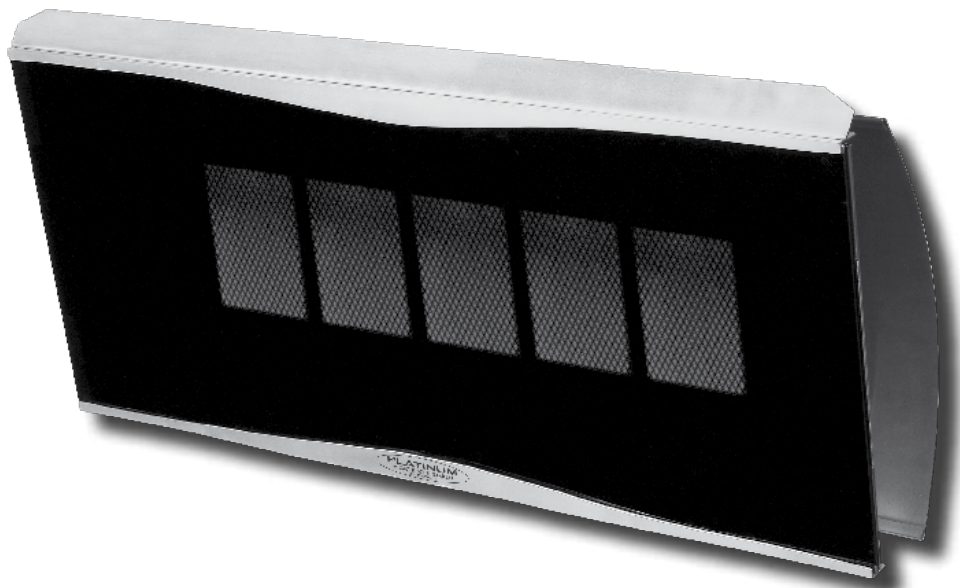

### DANGER

If you smell gas:

1. Shut off gas to the appliance
2. Extinguish any open flame
3. If odor continues, keep away from the appliance and immediately call your gas supplier or fire department.



WARNING: For Outdoor or Amply Ventilated area use and for NON RESIDENTIAL INDOOR APPLICATION



### WARNING

Do not store or use petrol or other flammable vapor and liquids in the vicinity of this or any other appliance.

This appliance to be connected only to reticulated gas & installed in accordance with AS/NZS 5601



WARNING: Improper installation, adjustment, alteration, service or maintenance can cause property damage, injury or death. Read the installation, operating and maintenance instructions thoroughly before installing or servicing this equipment.

This manual contains important information about the assembly, operation, and maintenance of Platinum Smart-Heat Heaters. Please pay close attention to the important safety information shown throughout this instruction manual. Any safety information will be accompanied by the following safety alert symbols:

DANGER, WARNING, IMPORTANT

- READ THIS MANUAL CAREFULLY before installing or servicing this product.
- Improper installation, operation, or maintenance can result in death, severe injury, or property damage.
- Installation must be carried out by Authorised person/s in accordance with AS5601 Gas Installation Code.
- This appliance is to be used ONLY for outdoor and non-residential indoor use (minimum room volume must be 250m<sup>3</sup>)
- When installed outdoors this appliance MUST be protected from rain.



**Head Office:** 10 Phiney Place, Ingleburn, Sydney, NSW 2565 Australia  
**T:** 1300 276 642 (within Australia) or +61 2 9748 3900 (from overseas) **F:** +61 2 9748 4289  
**E:** [info@bromicheating.com](mailto:info@bromicheating.com) **W:** [www.bromic.com.au](http://www.bromic.com.au)

*Note: Bromic Heating reserves the right to make changes to specifications, parts, components and equipment without prior notification.  
This Installation, operation and service manual may not be reproduced in any form with prior written consent from Bromic Heating.*

# CONTENTS

IMPORTANT NOTES & WARNINGS	4
PRODUCT OVERVIEW	5
PRODUCT DESCRIPTION	5
SPECIFICATIONS	5
GENERAL INFORMATION	6
PRODUCT FEATURES	6
INSTALLATION REQUIREMENTS	6
GAS REQUIREMENTS	6
INSTALLATION CLEARANCES	7
INSTALLATION INSTRUCTIONS	8
HEATER INSTALLATION INSTRUCTIONS	8
GAS SUPPLY INSTALLATION	12
POWER SUPPLY INSTALLATION	12
LEAKAGE TEST	12
OPERATING INSTRUCTIONS	13
TURNING THE APPLIANCE ON	13
TURNING THE APPLIANCE OFF	13
SERVICING	13
REGULAR SERVICE REQUIREMENTS	13
EXTERIOR SERVICING	13
CARE AND MAINTENANCE	13
OPTIMUM MOUNTING DISTANCE	14
OPERATION DATA - BRAHMA CONTROL BOX	14
OPERATION DATA - WHITE RODGERS VALVE	15
WIRING DIAGRAM	16
REPLACEMENT PARTS	17
POST-INSTALLATION REPORT	18
TROUBLESHOOTING	19
APPENDIX A	20
WARRANTY	23

# IMPORTANT NOTES AND WARNINGS

## WARNING

- THIS APPLIANCE SHALL NOT BE INSTALLED OR USED IN RESIDENTIAL DOMESTIC INDOOR AREAS
- DO NOT PLACE ARTICLES ON OR AGAINST THIS APPLIANCE
- DO NOT USE OR STORE FLAMMABLE MATERIALS NEAR THIS APPLIANCE
- DO NOT SPRAY AEROSOLS OR FLAMMABLE MATERIALS IN THE VICINITY OF THIS APPLIANCE WHILE IT IS IN OPERATION

Failure to follow the warnings and instructions in this manual could result in severe personal injury, death or property damage.

- This Installation, Operation and Service manual should not be removed from the site of installation.
- This Appliance is for outdoor and non-residential indoor areas only. (see attached diagrammatical representations of outdoor areas "Appendix A").
- Any guard or other protective device removed for servicing (conducted by an authorised person) must be replaced before operating the heater.
- Adults and children should stay away from high temperature surfaces to avoid burns or other serious personal injury.
- Children should be carefully supervised when they are in the area of the heater.
- Clothing or other flammable materials should not be hung from the heater or placed on or near the heater.
- Do not perform maintenance until heater has been turned off, power disconnected, and heater temperature has cooled to room temperature.
- Do not expose the burner to water or moisture. The appliance is to be protected from rain.
- Do not use the heater if any of these parts are exposed to water until the appliance is inspected or repaired by an authorised service person.
- The installer is to ensure that the requirements of the local authority, local gas fitting regulations, municipal building codes, and any other relevant statutory regulations are carried out.
- Certain materials or items, when stored under or near the appliance, will be subjected to radiant heat and could be seriously damaged. Ensure combustible materials eg. overhead structures, walls, floors, furniture, fixtures and plants must be kept 1100mm from the top and side.
- The whole gas system, hose assembly, regulator, pipes, and burner should be inspected for damage and leaks before use and at least annually by an authorized person for the life of the heater.
- All leak tests should be done with a soap solution. Never use an open flame to check for leaks.
- Do not use the heater until all connections have been leak tested by an authorised person.
- Inspect the hose assembly before each use of the appliance.
- The hose assembly must be replaced prior to the appliance being put into operation if there is evidence of

excessive abrasion or wear, or if the hose is damaged.

- The replacement hose assembly must be AGA approved.
- The hose assembly is not to be located in areas where the hose may be subject to accidental damage.
- This radiant heater is NOT intended to be installed on recreational vehicles and/or boats.
- Repair to be carried out ONLY by an authorised person.
- Improper installation, adjustment, or alteration can cause personal injury, property damage, or even death.
- Do not attempt to alter the unit in any manner.
- Ensure that the heater is never used without an AGA approved pressure limiting regulator
- Remove transit protection before use.
- Never operate the heater in an explosive environment such as areas where petrol or other flammable liquids or vapours are stored.
- Turn off the gas supply immediately if smell of gas is detected.
- Do not paint any surface of the heater.
- Do not throw objects at Glass facia.
- If Glass facia breaks, discontinue use, disconnect power and gas and isolate area affected by breakage.
- Control compartment, burner and circulation air passageways of the heater must be kept clean. Frequent cleaning may be required as necessary.
- Turn Gas Supply off when not in use.
- Check the heater immediately if any of the following occurs:
  - » The heater does not reach temperature.
  - » The burner makes popping noise during use (a slight noise is normal when the burner is ignited or extinguished).
- Young children should be supervised to ensure that they don't play with the appliance.
- This appliance is not intended for use by young or infirm persons unless they have been adequately supervised by a responsible person to ensure that they can use the appliance safely.
- Check for damage to the appliance regularly. If damage to the cord, plug or appliance is suspected, discontinue use immediately and contact the supplier or qualified person for repair.
- If the cord, plug or appliance is damaged, unplug from the outlet, discontinue use immediately, and only an authorised person or similar may repair the unit.
- Avoid inhaling fumes emitted from the heater's first use. Smoke and odour from the burning of oils used in manufacturing will appear. Both the smoke and odour will dissipate after approximately 30 minutes.
- Ensure that a watertight seal is maintained on the electrical control box at all times
- Regularly check for damage to the rubber seals. If damage to the rubber seals is suspected, discontinue use immediately, switch off power and contact the place of purchase or authorised service technician for repair.

# PRODUCT OVERVIEW

## PRODUCT DESCRIPTION

The Platinum Smart-Heat Gas Radiant Heaters are designed to provide effective outdoor heating to both commercial and residential premises whilst offering a unique and appealing design. Radiant gas burners provide heat which is passed through a translucent high temperature ceramic medium to provide effective and even heating and maximum comfort to users.

The heaters incorporate full function electronic controls, allowing them to be operated remotely from a conveniently located switch. The heaters have been designed to withstand the rigors of the outdoors and will operate effectively in high wind applications.

## SPECIFICATIONS

	PLATINUM Smart-Heat 300		PLATINUM Smart-Heat 500	
Gas type	LPG	NATURAL GAS	LPG	NATURAL GAS
Manufactured by	BROMIC HEATING PTY LTD			
AGA Approval No.	7289	7289	7289	7289
Gas Consumption	25 MJ/hr	25 MJ/hr	42 MJ/hr	42 MJ/hr
Gas Type	Propane Gas (LPG) Only	Natural Gas	Propane Gas (LPG) Only	Natural Gas
Gas Pressure	2.75 KPA	1 KPA	2.75 KPA	1 KPA
Injector Size	0.8mm	1.4mm	0.8mm	1.4mm
Weight	15kg	15kg	20kg	20kg
Voltage	220-240V	220-240V	220-240V	220-240V
Current	>1 Amp	>1 Amp	>1 Amp	>1 Amp

## PLATINUM SMART-HEAT HEATER DIMENSIONAL DETAILS

Without Heater Deflector

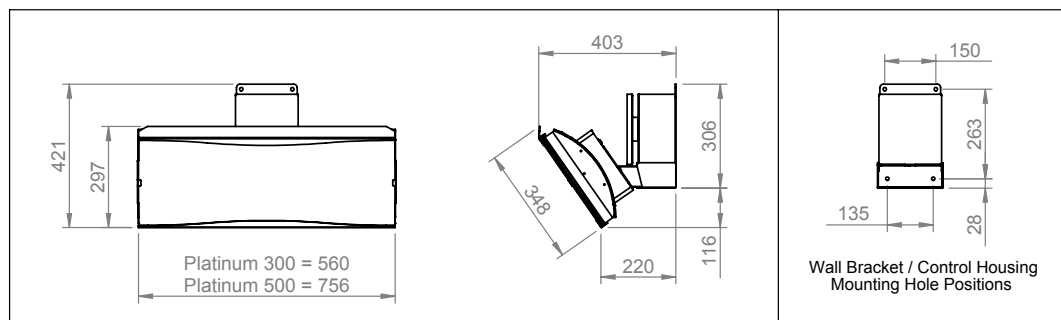

With Heater Deflector

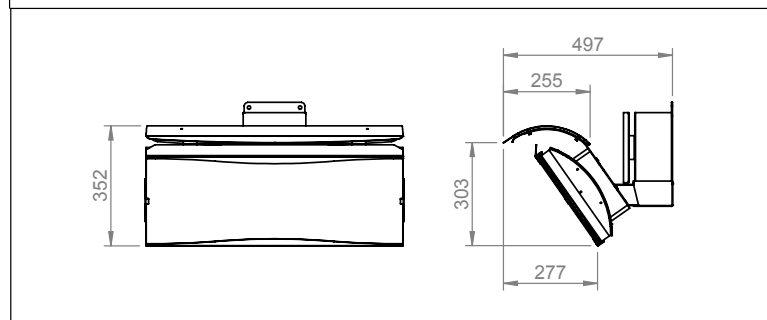

### ⚠ IMPORTANT

This appliance is NOT approved for indoor domestic use and must be installed by authorised persons only in accordance with AS5601-2010 Gas Installation Code.

This appliance is to be protected from rain. Install under a protective cover.

## GENERAL INFORMATION

The Platinum Smart-Heat Gas radiant heaters are suitable for outdoor and non-residential indoor spaces. In addition to the installation instructions provided, authorised installers must abide by the Australian installation code AS-5601-2010. Please note that these standards are subject to change.

The heater is designed to function in winds up to 18Km/h. The heater is subject to reduced performance or failure in adverse weather conditions such as high wind or extreme saturation.

## PRODUCT FEATURES

Platinum gas radiant heaters are revolutionising the commercial outdoor and indoor heating industry by introducing groundbreaking benefits never seen before in traditional gas or electric heaters. Platinum heaters have set the industry benchmark with stylish good looks and world-first innovation.

Platinum heaters excel in the areas of:

- Aesthetic appeal
- Innovation
- Performance
- Flexibility
- Cost effectiveness

For more detailed product information, visit [www.platinumheating.com](http://www.platinumheating.com)

## INSTALLATION REQUIREMENTS

### IMPORTANT

This appliance shall only be used in above ground open-air situations with:

- natural ventilation
- without stagnant areas
- where gas leakage and products of combustion are rapidly dispersed by wind and natural convection

Any enclosure in which the appliance is used shall comply with one of the following:

1. An enclosure with walls on all sides, but at least one permanent opening at ground level (ref. Appendix A, Example 1)
2. Within a partial enclosure that includes an overhead cover and no more than two walls (ref. Appendix A, Example 2)
3. Within a partial enclosure that includes an overhead cover and more than two walls, the following shall apply:
  - At least 25% of the total wall area is completely open (ref. Appendix A, Example 4), and
  - At least 30% of the remaining wall area is open and unrestricted (ref. Appendix A, Example 4)
4. In the case of Using this appliance/s for non-residential indoor use:
  - This appliance must not be used in a room smaller than 250 cubic meters (ref. Appendix A, Example 5)
  - This appliance must only be used in a well ventilated area (ref. Appendix A, Example 5)

Note: The definition of outdoors is an above ground open-air situation with natural ventilation, without stagnant areas, where gas leakage and products of combustion are rapidly dispersed by wind and natural convection.

### GAS REQUIREMENTS

#### Platinum LPG Models:

- Use Propane (LPG) gas only
- The approved inlet pressure to the appliance is 2.75KPA

#### Platinum Natural Gas Models:

- Use Natural Gas Only
- Always use Bromic Natural Gas Governor (supplied) – Model: BM-WF1A (AGA No. 5149)
- Ensure that Inlet pressure to the regulator does not exceed 5KPA
- The approved inlet pressure to the appliance is 1.0KPA

# INSTALLATION REQUIREMENTS CONTINUED...

## INSTALLATION CLEARANCES

When selecting the installation location for the Platinum Smart-Heat Heaters, the following mounting clearances should be followed.

Care should be taken to ensure that the heater is not installed:

- Where heat/ignition can cause damage to gas cylinders/lines
- Near other combustible materials
- In open locations subject to rain
- In indoor residential locations
- In areas without sufficient clearances (refer below)

Note: When Installing with No protective cover, the following installation clearances shall apply:

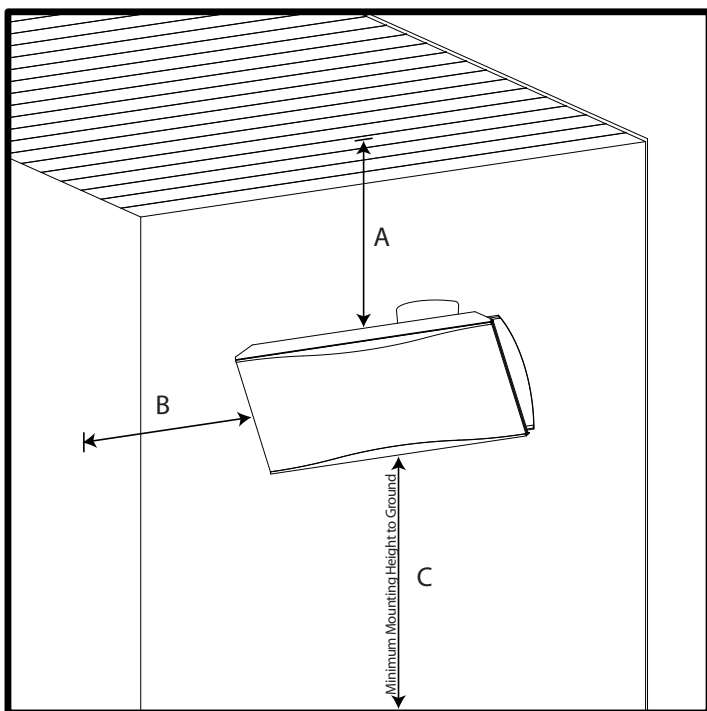

The stated clearance to combustible materials represents surface temperature of 65°C above room temperature. Building material with a low heat tolerance (such as plastic, vinyl siding, canvas, tri-ply etc.) may subject to degradation at lower temperature. It is the installer's responsibility to assure that adjacent materials are protected.

Note: When installing with the Platinum Smart-Heat Heat Shield (Part No. 2620165 or 2620166) the following installation clearances shall Apply:

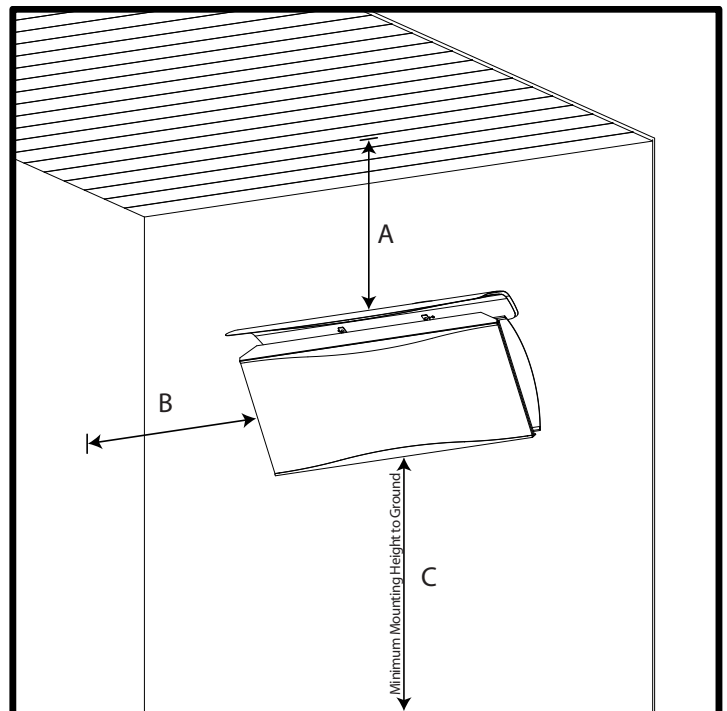

Minimum height to combustible materials			
Model	A	B	C
300 Series	1100mm	1100mm	2000mm* (Outdoor areas) 2500mm* (Non-residential indoor)
500 Series	1100mm	1100mm	2000mm* (Outdoor areas) 2500mm* (Non-residential indoor)

Minimum height to combustible materials			
Model	A	B	C
300 Series	350mm	1100mm	2000mm* (Outdoor areas) 2500mm* (Non-residential indoor)
500 Series	350mm	1100mm	2000mm* (Outdoor areas) 2500mm* (Non-residential indoor)

\*Bromic recommended minimum installation height. Local authority regulations and building codes must be checked prior to installation.

\*Bromic recommended minimum installation height. Local authority regulations and building codes must be checked prior to installation.

### IMPORTANT

In the Case of appliances intended for non-residential indoor use:  
This appliance must not be used in a room smaller than V cubic metres.

Where V = Five (5) times the rated gas consumption (MJ/h).

NOTE: For example in the case of an appliance with a rated gas consumption of 20 MJ/h, V = 5 x 20, 100 cubic metres.

### IMPORTANT

This appliance must only be used in a well ventilated area.

# INSTALLATION INSTRUCTIONS

## HEATER INSTALLATION INSTRUCTIONS

### WARNING

This appliance must be installed and used in accordance with AS5601-2010 Gas installation standard and must meet all the requirements stipulated in the "Installation Requirements" section of this manual.

### WARNING:

Installation should be done by a qualified service person.

### CAUTION

Please see specifications for the weight of the Heater. The installer of the Platinum Smart-Heat Series Radiant Heaters must comply with all relevant State Occupational Health & Safety Regulations.

#### 1. Mount Wall Bracket/Control Housing To Wall:

- Remove Wall Bracket/Control Housing From Packaging
- Place the mounting bracket in position and mark the fixing hole location on the wall. Drill holes using appropriate drill size and type.
- Attach the bracket to the wall using appropriate fixtures

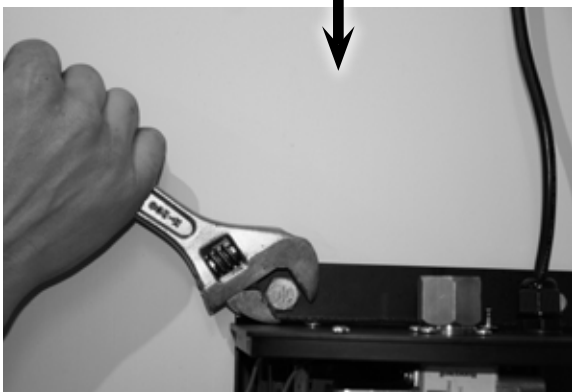
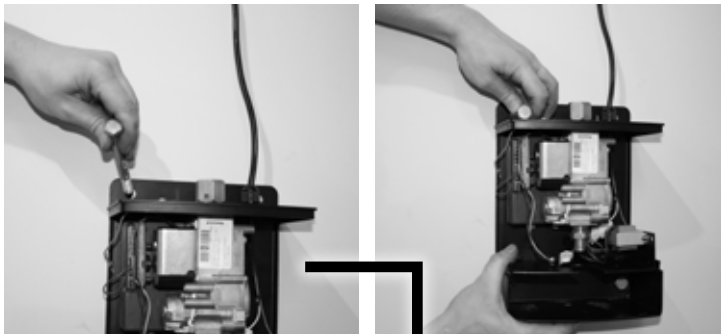

### IMPORTANT

The Heater shall be firmly and securely attached to the wall. **For Brick and masonry**, use M8 "Flush Head" "Dynabolts" (or equivalent). **For Wood / Timber fixtures**, use suitable screw fixings no less than 60mm in length.

### WARNING

When mounting wall bracket/ control housing, ensure the anchoring to the structure is of sufficient strength, quality and workmanship to support the weight of the heater and any other load that could be applied to the fixture.

2. Connect AGA approved Flexible Gas Connector (as supplied) to the inlet fitting on the heater using 2 wrenches to tighten. Leak Test by applying compressed air (1/2" PSI) to open end of flexible hose. Spray gas fittings with a soapy water solution and Check for leaks. Alternatively, leak check can be done after assembly using inspection hole on bracket arm. (see. leakage test section of this manual).

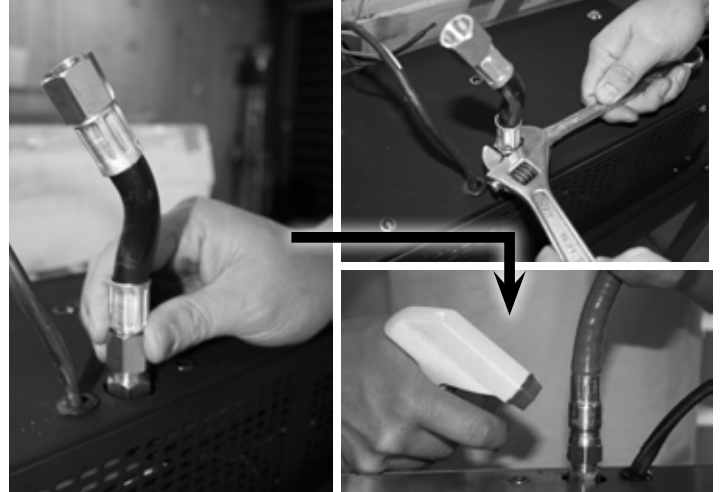

#### 3. Fix Mounting Arm to the back of the heater –

- Slide Gas Connector and Wiring Harness inside the centre of the arm and have them exit through the shaped cut-out on top surface of the arm
- Ensure that the arm faces downwards at a 55° angle
- Position the 4 mounting holes on the arms plate over the corresponding fixtures on the heater – Manipulate the gas hose as necessary to allow for correct alignment
- Insert and tighten 4 M6 bolts as provided to fit mounting arm to heater.

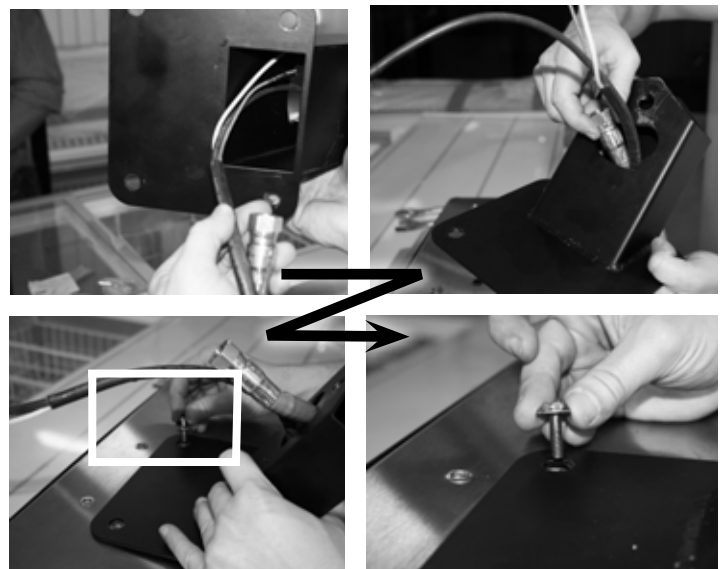



# INSTALLATION INSTRUCTIONS CONTINUED...

## 4. Attach Heater to Wall Bracket/Control Housing

- Remove Front Cover from Control Housing
- Attach Heater to Wall Bracket/Control Housing by inserting Mounting Arm into lower channel of Wall Bracket. Ensure that the Gas Hose and Wiring Harness slide through the groove on top side of the control Housing's lower channel and remain undamaged by the metal's edges during assembly.
- It may be necessary to manipulate the gas Hose so that the arm can slide into place.

**TIP:** Do not install the mounting pin at this point.

- Spray soapy water on the arm to ease the sliding.

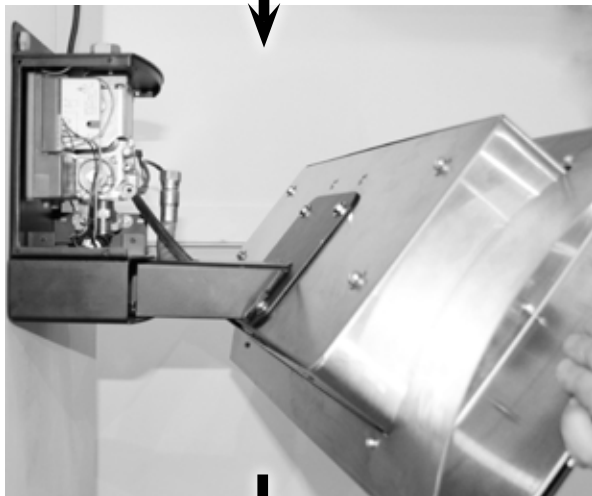

## 5. Connect the AGA approved flexible connector to the Gas Valve Outlet Fitting

- Position heater and hose so that the gas hose and fitting are in alignment
- NOTE: ensure that the hose nut and valve fitting are parallel to one another and threads are engaged correctly before tightening! Incorrect installation can cause gas leaks and damage components.

**TIP:** Sliding the mounting arm inside the control housing's channel can help accurately Position the Gas hose in place under the gas valve's fitting.

- Spanner Tighten using 2 wrenches, and leak test using soapy water (see section "leakage test")



# INSTALLATION INSTRUCTIONS CONTINUED...

## 6. Insert Pivot Bolt

- Position Arm so that the rear hole's on the mounting arm and Control Housing are in alignment
- Insert Bolt and washer (as supplied) through Control Housing and Mount Arm, using the hole located on the bottom surface of the Control Housing, towards the rear. Spanner tighten in place
- Select desired heater angle and insert the M6 Bolt and washer (as supplied) through the bottom surface of Control Housing into the mounting arm, using the corresponding hole. (Heaters angle will be 0°, 10° or 20°). Spanner tighten in place

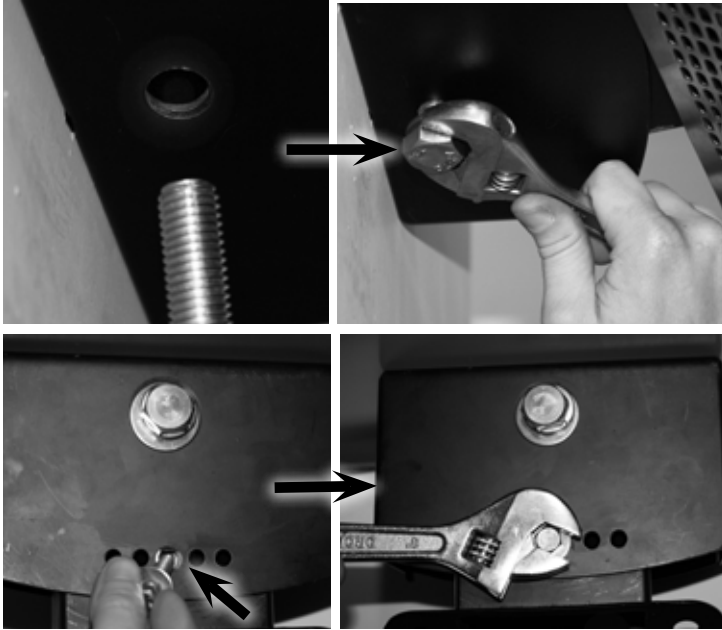

### **IMPORTANT**

Electrical connections must be completed by trained and authorized electrical technicians only!

## 7. Connect the 3 wires from the heater by carefully following the instructions below

### For Honeywell Control

- Disconnect Honeywell control from Honeywell gas valve by unscrewing retaining screw and pulling away from gas valve



- Insert Black Ignitor Cable directly into control box using 2.8mm spade connector, located on the side of the controller



- Insert White Ionisation Cable directly into control box using 4.75mm spade connector, located on the side of the controller



- Insert Earth Terminal over earth tab, attached to body of control housing and marked with Earth

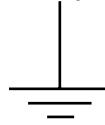

### Symbol

- Re-connect Honeywell control to the gas valve by positioning the controller's inbuilt Molex plug over the gas valve's connector and carefully slide into place. Fix in place using the retaining screw.



# INSTALLATION INSTRUCTIONS CONTINUED...

## For White Rodger

- Insert Black Ignitor Cable directly into Control Box at terminal marked:

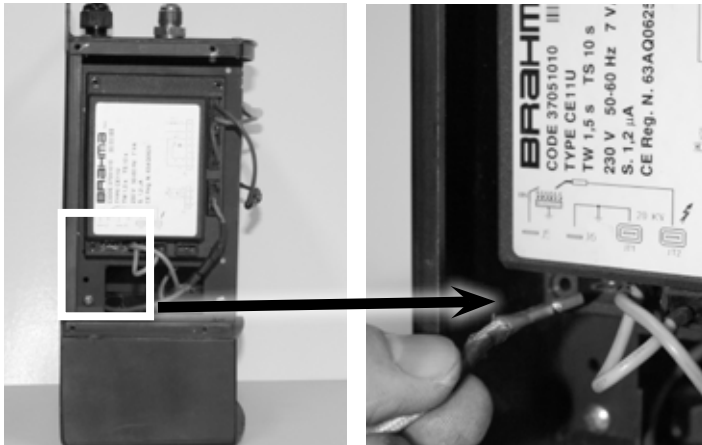

- Insert White Ionisation Cable directly into Control Box at terminal marked:

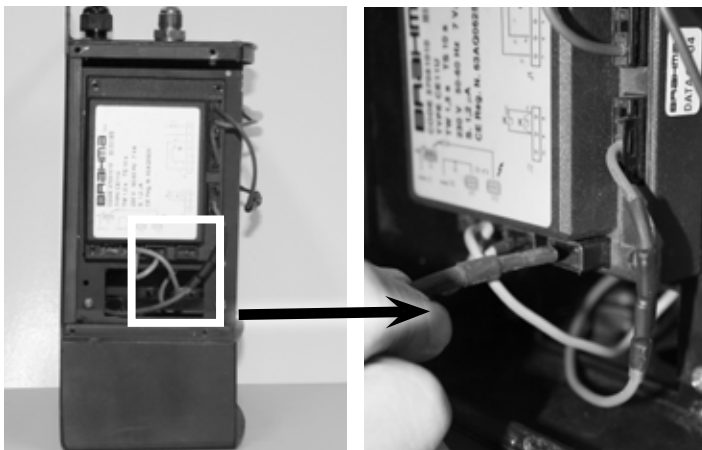

- Insert Earth Terminal over Earth Tab, attached to side of Wall Bracket Housing and marked with the symbol:

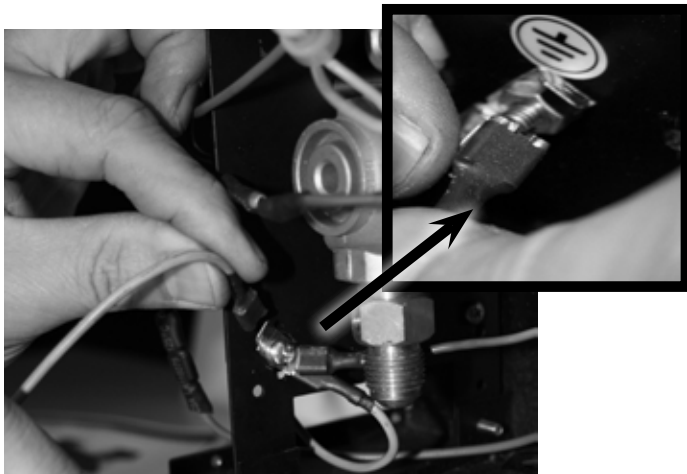
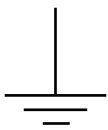

1. Connect gas inlet fitting to mains gas supply in accordance with local gas installation code and gas supply installation section of manual. Leak test with soapy water.



9. Fix Front cover to control housing using the 4xM4 screws provided.



10. Main Power supply connection is to completed in line with instructions in the "Power supply installation" section of this manual.

### IMPORTANT

Ensure that a water tight seal is maintained.

### IMPORTANT

After gas installation and electrical installation is complete, all gas lines should be tested for leaks using a soapy water solution. See Section titled "Leakage Test" for further information. Ensure gas pressure meets the requirements outlined in Gas Supply Installation above.

## GAS SUPPLY INSTALLATION

### IMPORTANT

- All gas supply installation work must be performed by trained and authorized person(s) and comply with the requirements of local Gas Installation Codes.
- All Piping Joints should be tested for leaks with a soapy water solution before use.
- Gas hose must be located out of pathway where people may trip over it, or in areas where the hose may be subject to accidental damage.

Verify the type of gas supply complies with the appliance rating plate, located at the back of the heater.

An approved manual isolating valve must be fitted before the heater in accordance with **local Gas Installation Codes**.

The inlet connection to the heater control box is a 3/8" SAE Male.



Tighten all the connections and then turn on the gas supply. Check for gas leakage with a soapy water solution. (See section titled "Leakage Test").

Do not use an open naked flame to check for leaks.

When the heater is operating, check gas pressure at the test point and ensure the manifold pressure to the heater is:

NG: 1KPA

LPG: 2.75KPA

Gas supply pressure must be limited to 5KPA. If gas line pressure exceeds this level, a separate pressure reducing regulator must be installed.

The appliance and its individual shutoff valve must be disconnected from the gas supply piping system during any pressure testing of that system at test pressures in excess of 1/2 psi.

The appliance must be isolated from the gas supply piping system by closing its individual manual shutoff valve during any pressure testing of the gas supply piping system at test pressures equal to or less than 1/2 psig.

## POWER SUPPLY INSTALLATION

### WARNING

This heater is equipped with a three-prong (grounding) plug for your protection against shock hazard and should be plugged directly into a properly grounded three-prong receptacle. Do not cut or remove the grounding prong from this plug.

The Platinum Smart-Heat Gas Heater comes standard with 900mm of power cord in addition to the Approved 3 pin power plug.

If an appropriate power socket is available, the heater can be plugged into this power socket and operated using the on/off switch supplied on the power socket. Alternatively, the power installation can be tailored to suit the site requirements by an Authorized Electrician.

Keep electrical supply cord away from any heated surface and flue gasses.

#### **Please Note:**

Platinum Smart-Heat Gas do not have their own on/off switch.

### WARNING

Ensure that power socket is switched off before plugging in power cord.

Operation should be controlled via the main power supply.

## LEAKAGE TEST

Gas connections on the heater are leak tested at the factory prior to shipment. A complete gas tightness check must be performed at the installation site due to possible mishandling in shipment or excessive pressure being applied to the heater. Check ALL connections.

- The heater must be checked with the gas supply turned on.
- Make sure the safety control valve is in the OFF position.
- Make a soap solution of one part liquid detergent and one part water. The soap solution can be applied with a spray bottle, brush or rag. Soap bubbles will appear in case of a leak.
- Turn the gas supply ON.
- In case of a leak, turn off the gas supply. Tighten any leaking fittings, then turn the gas supply on and recheck.
- Never leak test while smoking.
- The following points **MUST** be leak checked before operation.

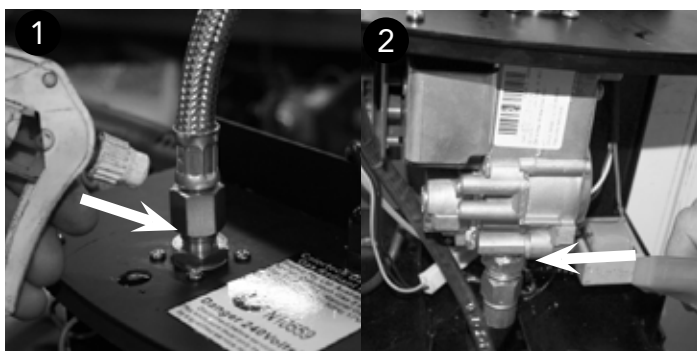

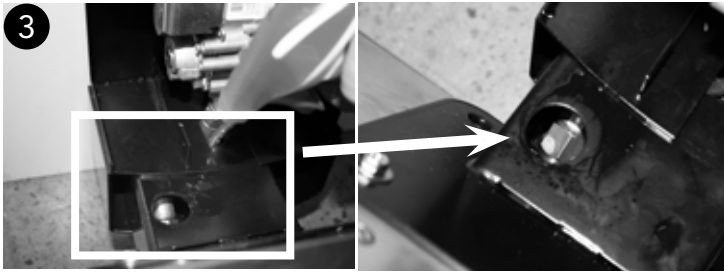

## HEAT-DEFLECTOR INSTALLATION

1. Assemble Heat Deflector following instructions supplied in the Heat Deflector carton.
2. Mount Heat Deflector to back of heater by loosening the two screws and secure brackets underneath washers. Re-tighten screws to original position using screw drivers.

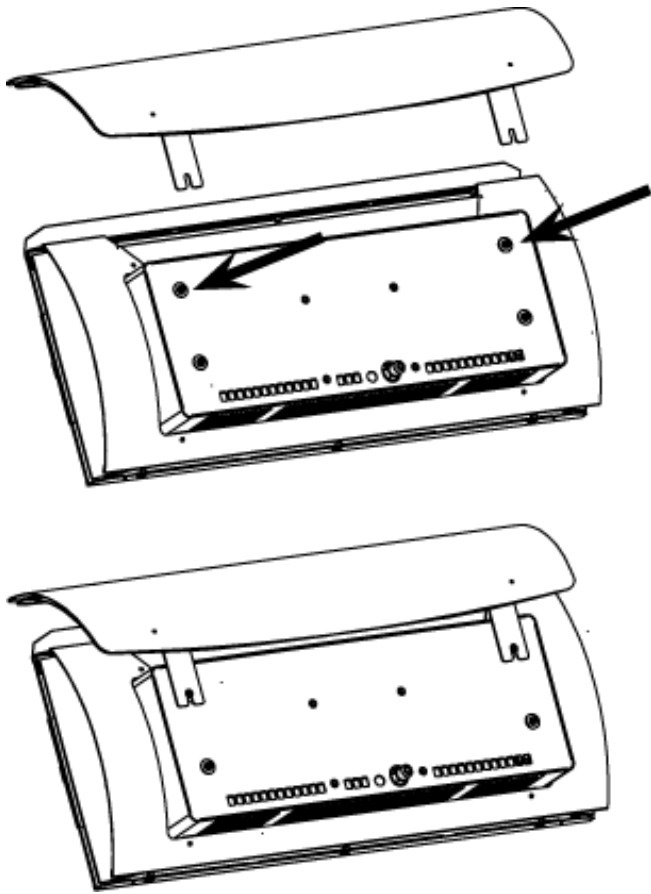

NOTE: Platinum Smart-Heat Heating recommends running power and gas lines, to the heater, inside the pole to reduce visibility and likelihood of damage.

## CEILING POLE INSTALLATION

### WARNING

When mounting ceiling pole, ensure the anchoring to the structure is of sufficient strength, quality and workmanship to support the weight of the heater and any other load that could be applied to the fixture. Note: Ceiling pole must be perpendicular (90deg) to the ground when mounted (irrespective of pitched or flat ceiling).

1. Mount Top Bracket to ceiling or support beam using suitable fixings no less than 60mm length.
2. Assemble pole to the mounting bracket using the M8x100mm and M19x100mm bolts, and fix using nuts and washers (as supplied).
3. Assemble both lower paddles to the pole (back to back) and insert 3 M10x100mm bolts and fix using nuts and washers (as supplied).
4. Fix Heater to Lower paddles using suitable fixtures.

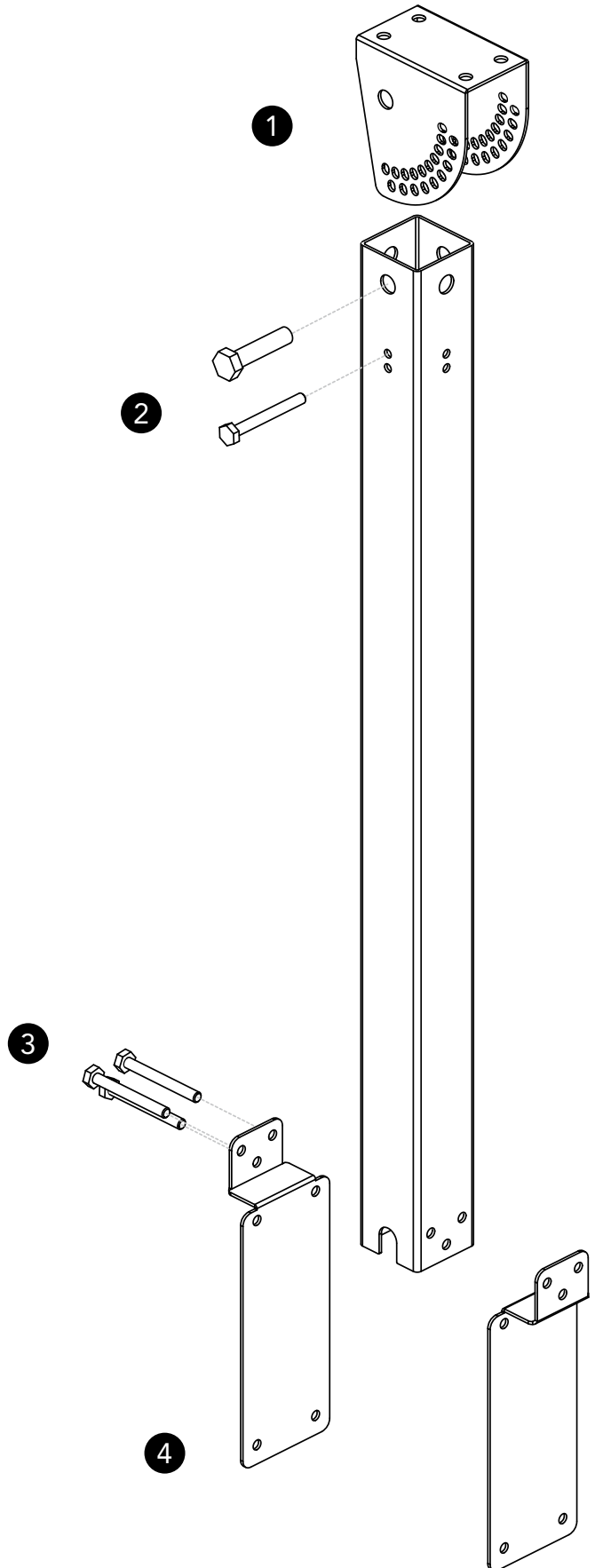

# OPERATING INSTRUCTIONS

## TURNING THE APPLIANCE ON

1. Ensure that gas installation and power installation has been carried out in accordance with the manufacturers instructions outlined in this document.
2. Turn on gas supply.
3. Ensure correct gas supply pressures are set.
4. Switch on power to heater.
5. If Gas heater does not light, turn power off.
6. Wait 5 seconds before turning power back on. If heater does not ignite after 5 attempts, consult the troubleshooting section of this manual, or contact Platinum Smart-Heat Heating Pty. Ltd for service information.

## TURNING THE APPLIANCE OFF

1. For temporary shutdown, turn off power.
2. For permanent shutdown, turn off power and shut off

gas supply.

NOTE: The appliance must be completely shutoff for a period of 5 minutes before being relighted.

### **IMPORTANT**

Check the heater immediately if any of the following occurs:

- The heater does not reach temperature.
- The burner makes popping noise during use (a slight noise is normal when the burner is ignited or extinguished).

**Note:** Avoid inhaling fumes emitted from the heater's first use. Smoke and odour from the burning of oils used in manufacturing will appear. Both the smoke and odour will dissipate after approximately 30 minutes.

### **Installers please Note:**

When the installation and testing is completed, make sure that the customer knows how to operate the heater. Leave the operating instructions with the customer.

## MAINTENANCE AND SERVICING

It is important that regular maintenance is carried out on the heater to maintain efficient operation. All maintenance should be carried out **ONLY** by authorized service personnel.

Control compartment, burner and circulation air passageways of the heater must be kept clean. Inspect and clean at least every six months or more frequently in adverse conditions.

Never obstruct the flow of combustion and ventilation air. Always keep the appliance area clear and free from combustible materials, gasoline and other flammable vapors and liquids.

Do not clean heater with cleaners that are combustible or corrosive.

### REGULAR SERVICE REQUIREMENTS

1. AGA approved Gas Hose, located within the mounting arm, must be checked at least once annually. The hose must be replaced if there is any evidence of excessive wear, or if the hose is damaged. The replacement hose assembly must be AGA approved with 3/8"SAE flared ends. To Check the Gas Hose, remove control housing cover by removing 8 screws and slide cover outwards. Alternatively, disassemble heater by reversing the installation instructions as outlined in Installation section of this handbook.
2. **VISUALLY CHECK BURNER FLAMES.** During heaters function visually check that all burners are alight and glowing hot. This can be done by observing the red glow through the translucent face, or by peering down the product combustion passageway. Note: A slight variation in colour is to be expected.

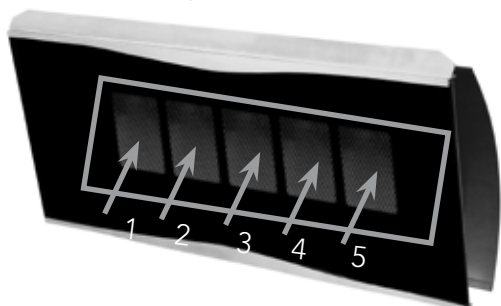

3. **Clean burners:** Burners can be cleaned by directing compressed air (max20PSI) at outlet ports. Avoid directing air at gasket material between ceramic tile and burner cup.
4. **Clean manifold and injectors:** Undo gas hose from gas valve outlet (heater should be switched off) and inject compressed air (max20PSI) down the inlet fittings.
5. **Clean dust and foreign matter from inside of heater housing:** Open up rear housing and clear dust using compressed air (max20PSI) and a damp cloth.
6. Remove debris, spider and insect nests from, control compartment, burner and circulation air passageways of the heater with heavy-duty pipe cleaner or compressed air to keep appliance clean and safe for use. Never clear ports or other openings with toothpicks or other articles that will break and block the ports.
7. In a salt-air environment, such as near an ocean, corrosion occurs more quickly than normal. Check frequently for corroded areas and repair them promptly.

### **IMPORTANT**

**More frequent cleaning may be required as necessary. It is imperative that control compartment, burners and circulating air passageways of the heater be kept clean.**

## EXTERIOR SERVICING

The exterior Platinum Smart-Heat Series Heater components are constructed from stainless steel, and high temperature coated black paint. For all exterior black parts (excluding fascia trims), a brushed finish has been used. This is not a coating and under prolonged use, may slightly discolour from high temperatures emitted by the heater. This is a normal occurrence and does not affect the operation of the appliance.

Replacement parts can be purchased to restore the heater to its original appearance from Platinum Smart-Heat Heating Pty Ltd. (Refer to parts list in manual).

## ! IMPORTANT

Do not apply any additional surface coating to the heater under any circumstances. Use of additional coating other than those applied during manufacture could result in hazardous reactions such as toxic fumes or fires. Additional coatings will void the warranty.

## OPTIMUM MOUNTING DISTANCE

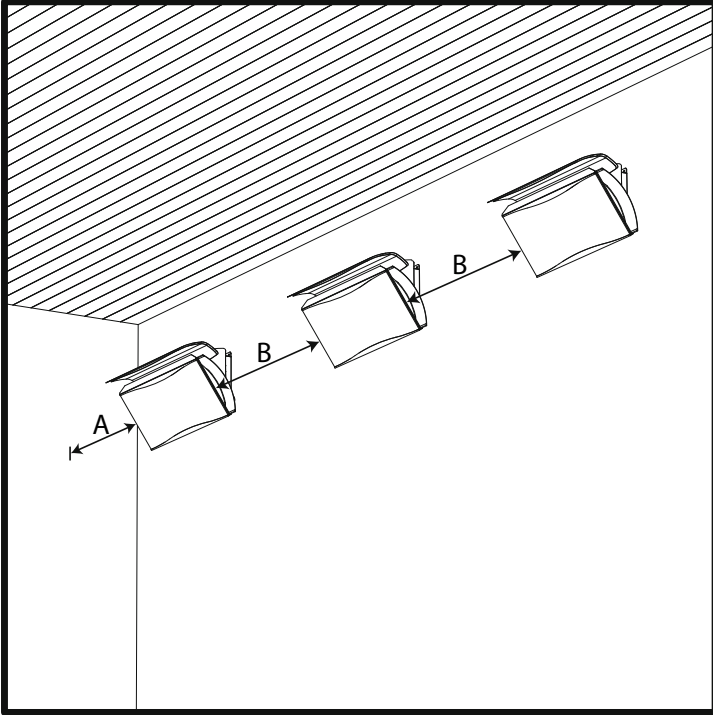

Model	A	B
3 - Burner	1100mm	2500 - 3500mm
5 - Burner	1100mm	2500 - 3500mm

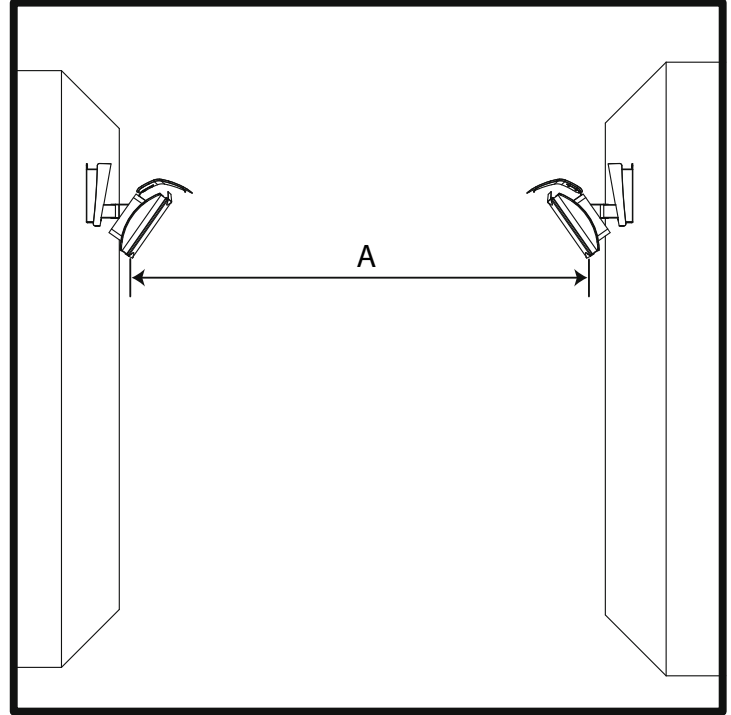

Model	A
3 - Burner	6000 - 7000mm
5 - Burner	8000 - 9000mm

## OPERATION DATA - HONEYWELL CONTROL BOX

The following operation sequence is valid only where the components are installed according to the manufactures assembly and installation instructions. Please do not modify the wiring configuration, gas train or any other part of the heater assembly.

### Application

The Honeywell electronic gas burner control system is suitable for atmospheric gas burners for non-permanent operation. Although the Honeywell unit is available non volatile lockout, its configuration in the Platinum Smart-Heat series heaters limits it to volatile lockout, i.e. the restart from this condition is possible by the interruption and subsequent restoration of the mains power supply.

### Features:

- Compliance with AGA standard for automatic gas burner flame monitoring and control systems
- Compliance with EN 298 (European standard for automatic gas burner flame monitoring and control systems)
- Compliance with AGA (Australian standard for automatic gas burner flame monitoring and control systems)
- Flame monitoring based on rectification property of the flame (ionisation)

### TECHNICAL DATA

Supply voltage	230V-50/60Hz
Operating temperature	-20°C +60°C
Ambient humidity	90%max at 40°C
Protection degree	IPX4
Timings:	
Self Check time	1.5 s
Safety time (TS)	25 s
Drop out time on running flame failure	1 s
Power consumption, at start up	10VA
Power Consumption, Running	4VA
Ignition	
Ignition Voltage	15kV with 40pF load
Spark repetition rate	33 Hz
Max. Cable length	1M
Recommended spark gap	0.14"
Consumption	2,5 VA
Spark energy	3 uAs

# OPERATION DATA - HONEYWELL CONTROL BOX CONTINUED...

## Directions for use

- Automatic controls are safety devices and shall not be opened. The manufacturer's responsibility and guarantee are invalid if the control is unduly opened.
- A regulation shutdown must occur every 24 hours to enable the unit to check its own efficiency (systems for non permanent operation)
- Connect and disconnect the unit only after switching off the power supply
- Avoid exposing the unit to dripping water
- Ventilation and the lowest temperature ensures the longest life of the control

## Electrical Installation

- Live and Neutral should be connected correctly; a mistake could cause a dangerous situation.
- Before starting the system check cables carefully for incorrect installation
- The earth terminal of the control, the metal frame of the burner and the earth on the mains supply must be well connected

## Operation

At every start, the control unit proceeds to a self-checking of its own components. During the pre-purge or waiting time (TW) the internal circuit makes a test of the flame signal amplifier. Extraneous light or fault in the amplifier will result in the simulation of a flame which will prevent the control from starting.

At the end of the waiting or pre-purge time, the gas valve is energised and the ignition device is operated. In this way, the safety time (TS) begins.

If a flame is detected during the safety time, the ignition device is inhibited and the gas valve remains energised.

If the control does not detect any flame signal during the safety time, at the end of safety time (TS), the unit proceeds to lockout and the gas valve and ignition device are switched off.

If the established flame signal is lost, (during the safety time or during operation thereafter) this will cause the ignition device to be reactivated within 1 second.

If the burner does not light within 25 seconds of ignition reactivation, the heater will enter failure lockout mode and must be reset.

# OPERATION DATA HONEYWELL VALVE:

The VK series gas control have been specially developed for application in domestic appliances. The Honeywell Gas Valve is a multi-functional control which incorporates an adjustable direct acting pressure regulator. It is designed for operation on 220/240V.

## Standard Specifications

- 3/8" SAE Male Thread connection
- Ambient Temperature Range of 0°C to 60°C
- Compact Size: 86.5mm x 63.5mm x 65.9mm
- 50mb Pressure Rating
- 3/8" x 3/8" SAE Inlet and Outlet
- Earthing terminal – 6mm spade tab
- Tamper resistant screws
- Top mounted coils that can be field replaced

## Adjust Regulator Pressure

- Unscrew the regulator cover.
- Unscrew the outlet plug to measure the outlet regulator pressure by using manometer.
- Adjust the pressure by turning the regulator screw clockwise or anti wise.
- Adjust the pressure according to appliance specification.

## IMPORTANT

Remember to place the regulator cover, outlet and inlet back on.

TECHNICAL DATA	
Max inlet working pressure	50 mbar
Installation group	Group 2
Operating Temperature	0°C to 60°C
Voltage Ratings	220/240VAC 50/60Hz .52A

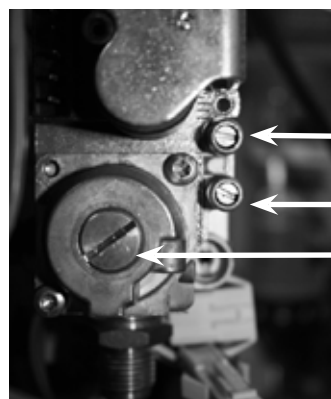

Inlet Pressure Test point

Outlet Pressure Test point

Regulator



# OPERATION DATA - BRAHMA CONTROL BOX

The following operation sequence is valid only where the components are installed according to the manufactures assembly and installation instructions. Please do not modify the wiring configuration, gas train or any other part of the heater assembly.

## Application

The Brahma electronic gas burner control system is suitable for atmospheric gas burners for non-permanent operation. Although the Brahma unit is capable of non volatile lockout, its configuration in the Platinum Smart-Heat series heaters limits it to volatile lockout, i.e. the restart from this condition is possible by the interruption and subsequent restoration of the mains power supply.

## Features

- Compliance with EN 298 (European standard for automatic gas burner flame monitoring and control systems)
- Compliance with AGA (Australian standard for automatic gas burner flame monitoring and control systems)
- Flame monitoring based on rectification property of the flame (ionisation)
- Two independent safety contacts in series on the gas valve output
- Electrical service life at max. declared loading > 250.000 operations
- Inbuilt ignition device with completely solid state design and high efficiency

TECHNICAL DATA	
Supply voltage	23V-50/60Hz
Operating temperature	-20°C +60°C
Ambient humidity	95%max at 40°C
Protection degree	IP00
Timings:	
Prepurge or waiting time	10 s
Safety time (TS)	10 s
Drop out time on running flame failure	< 1 s
Power consumption, at start up	10VA
Power Consumption, Running	7VA
Ignition	
Ignition Voltage	20kV with 30pF load
Spark repetition rate	25 Hz
Max. Cable length	2 m
Recommended spark gap	2-4mm
Consumption	2,5 VA
Spark energy	15 mJ

## Directions for use

- Automatic controls are safety devices and shall not be opened. The manufacturer's responsibility and guarantee are invalid if the control is unduly opened.

- A regulation shutdown must occur every 24hours to enable the unit to check its own efficiency (systems for non permanent operation)
- Connect and disconnect the unit only after switching off the power supply
- Avoid exposing the unit to dripping water
- Ventilation and the lowest temperature ensures the longest life of the control

## Electrical Installation

- The applicable state and Australian standards (eg. AS3350) regarding electrical safety must be respected.
- Live and Neutral should be connected correctly; a mistake could cause a dangerous situation.
- Before starting the system check cables carefully for incorrect installation
- The earth terminal of the control, the metal frame of the burner and the earth on the mains supply must be well connected

## Operation

At every start, the control unit proceeds to a self-checking of its own components. During the pre-purge or waiting time (TW) the internal circuit makes a test of the flame signal amplifier. Extraneous light or fault in the amplifier will result in the simulation of a flame which will prevent the control from starting.

At the end of the waiting or pre-purge time, the gas valve is energised and the ignition device is operated. In this way, the safety time (TS) begins.

If a flame is detected during the safety time, the ignition device is inhibited and the gas valve remains energised.

If the control does not detect any flame signal during the safety time, at the end of safety time (TS), the unit proceeds to lockout and the gas valve and ignition device are switched off.

If the established flame signal is lost, (during the safety time or during operation thereafter) this will cause the ignition device to be reactivated within 1 second.

If the burner does not light within 10 seconds of ignition reactivation, the heater will enter failure lockout mode and must be reset.

# OPERATION DATA - WHITE RODGER VALVE:

The White Rodgers Gas Valve is a compact multi-functional control which incorporates an adjustable direct acting pressure regulator. It is designed for quiet operation with cushioned solenoid stops and operates on 220/240V.

## Standard Specifications

- Inlet Screen – will filter to 180 microns
- Quiet operation
- Ambient Temperature Range of 0°C to 60°C
- Compact Size: 86.5mm x 63.5mm x 65.9mm
- 50mb Pressure Rating
- Class 'B' Group 2 Direct Acting Solenoid Valves with high sealing force
- 3/8" x 3/8" (BSP PI.) Inlet and Outlet
- Opening time < 0.25 seconds
- Closing time < 0.25 seconds
- Earthing terminal – 6mm spade tab
- Tamper resistant screws
- Top mounted coils and electronics that can be field replaced without entering the gas stream.

TECHNICAL DATA	
Max Working pressure	50 mbar
Installation group	Group 2
Operating Temperature	0°C to 60°C
Regulator adjustment range	9.2 to 13.7 mbar
Voltage Ratings	220/240VAC 50/60Hz .52A

## ELECTRICAL DIAGRAM

SEE INSTRUCTION MANUAL FOR DETAILS ON HOW TO CONNECT THE ELECTRICAL COMPONENTS.

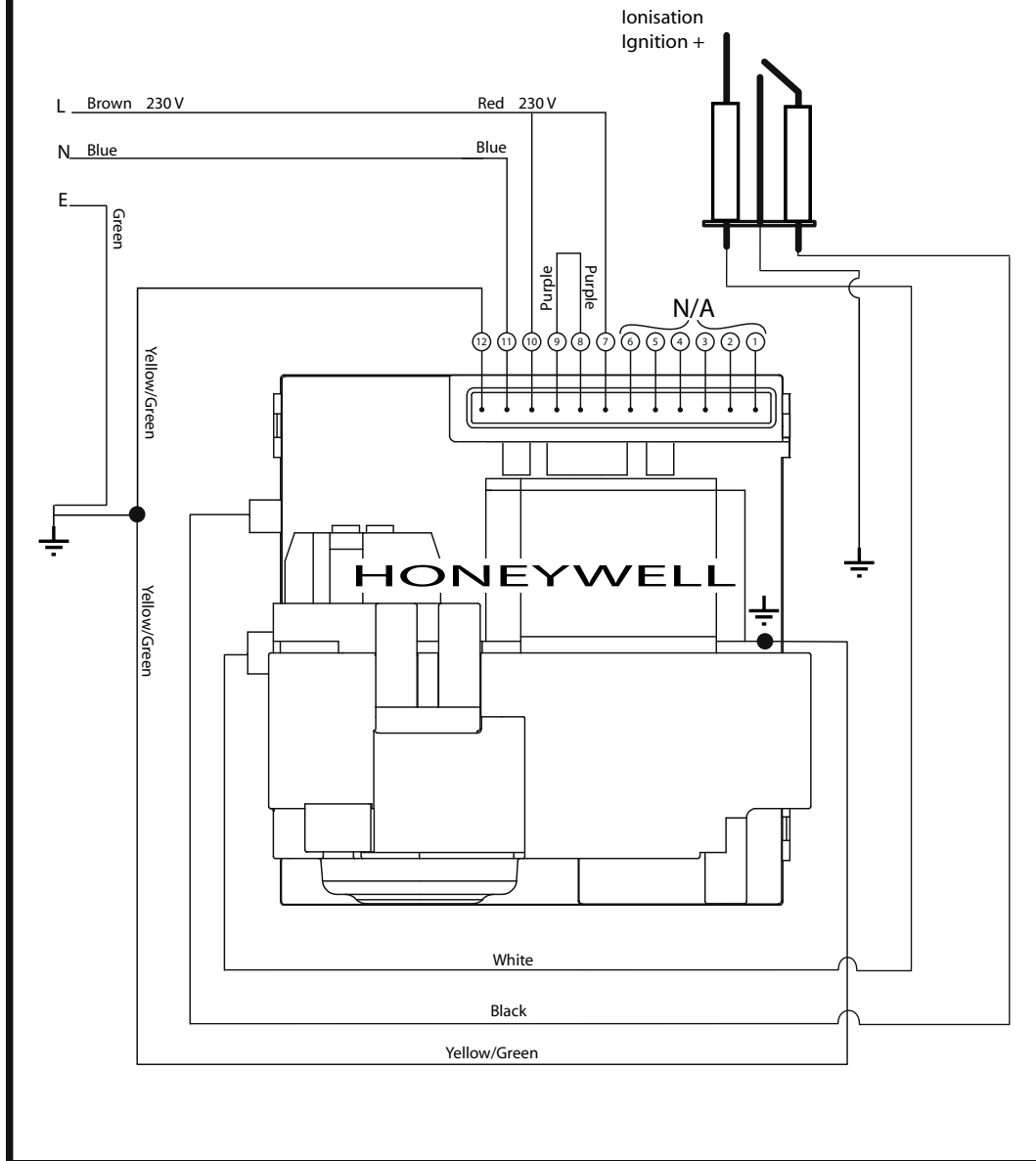

# ELECTRICAL DIAGRAM

SEE INSTRUCTION MANUAL FOR DETAILS ON HOW TO CONNECT THE ELECTRICAL COMPONENTS.

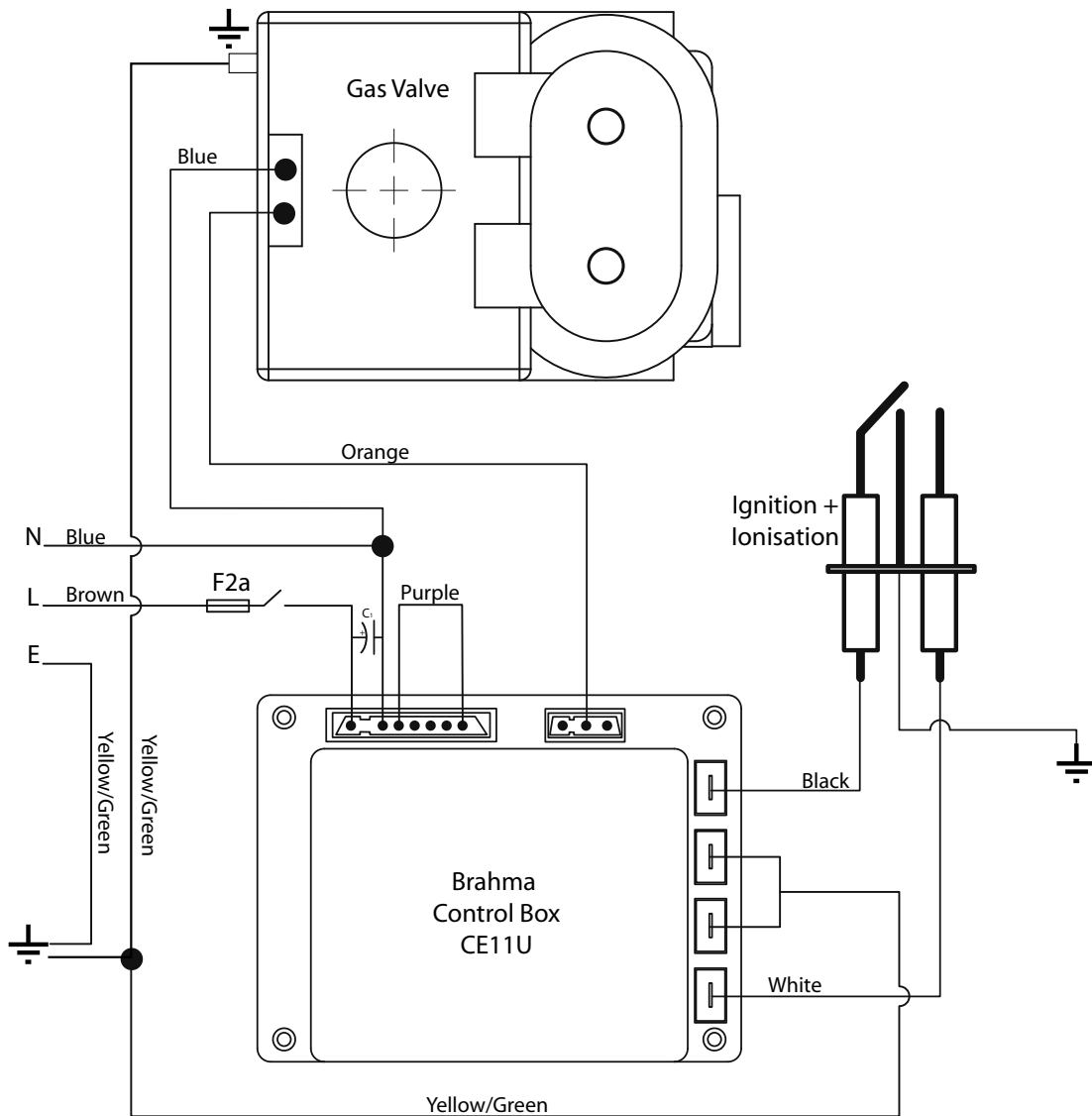

# REPLACEMENT PARTS

## White Rodger

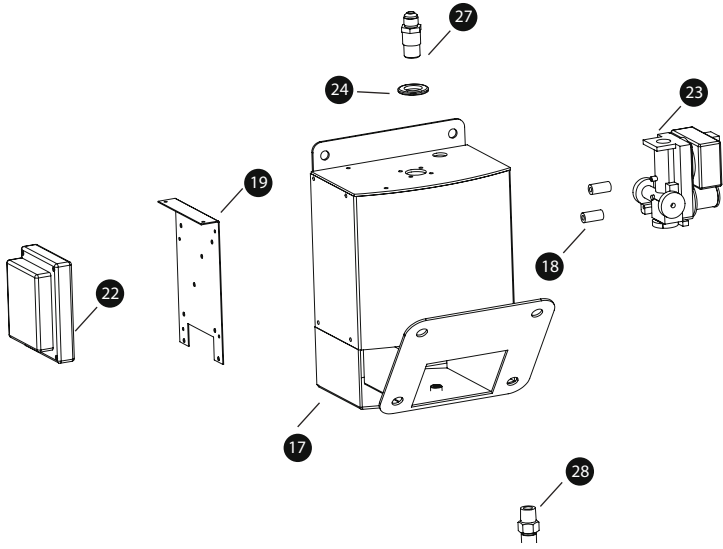

## Honeywell

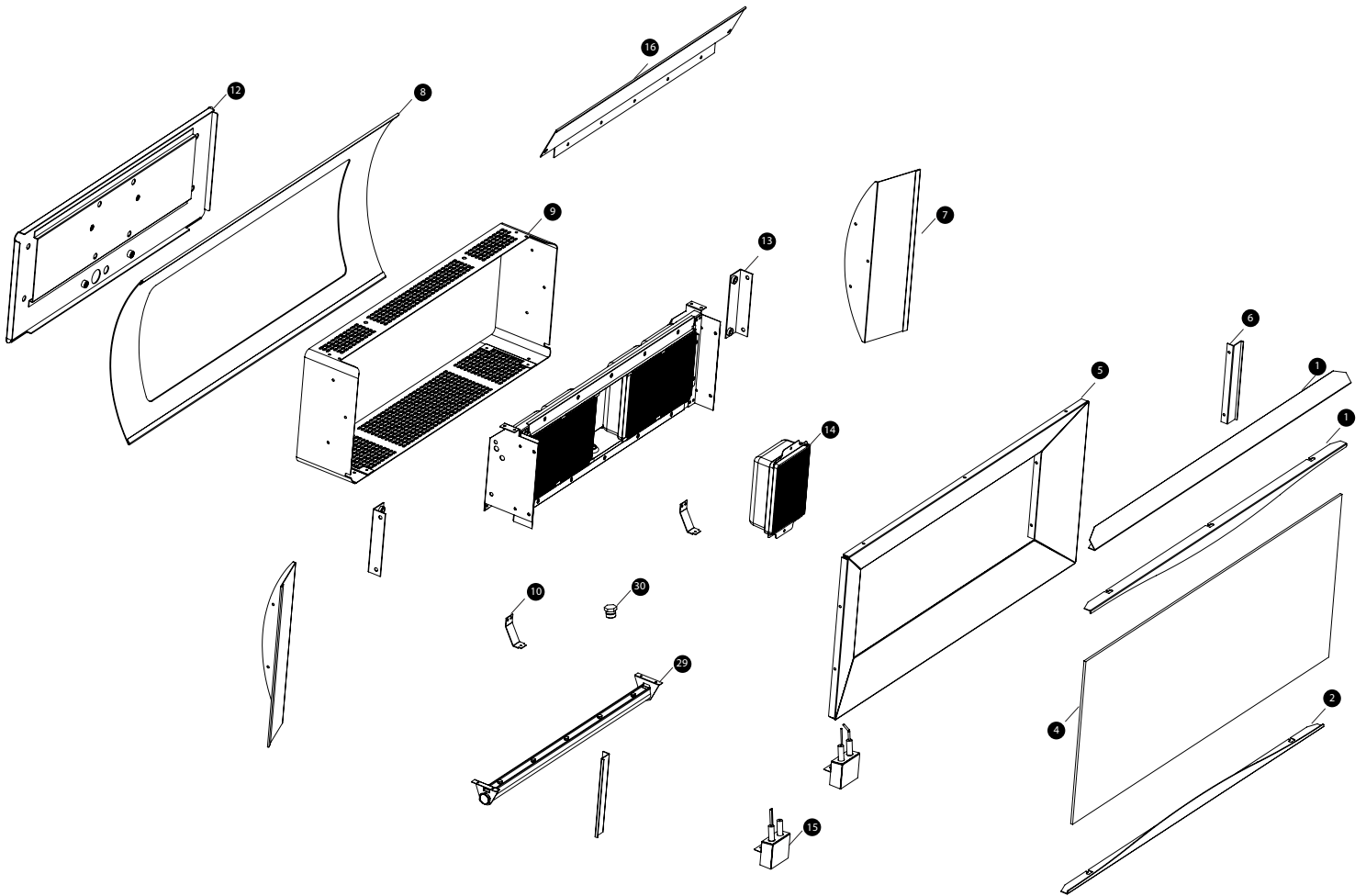
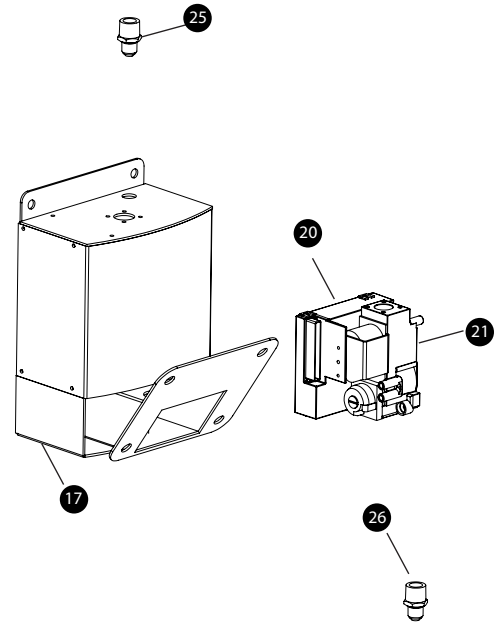

# REPLACEMENT PARTS DESCRIPTION

No.	Description	Part No. 300 Series	Part No. 500 Series
1	Glass Retainer - Top	2620801-1	2620802-1
2	Glass Retainer - Bottom	2620803	2620804
3			
4	Glass	2620807	2620808
5	Reflector Assembly	2620809	2620810
6	Glass Retainer Side	2620811	2620811
7	Side Shield	2620812	2620812
8	Sail	2620813	2620814
9	Rear Housing	2620815	2620816
10	Rear Housing Mount (Top)	2620817	2620817
11	Rear Housing Mount (Bottom)	2620818	2620818
12	Rear Cover Assembly	2620819	2620820
13	Rear Cover Mount	2620821	2620821
14	Burner	2620822	2620822
15	Wiring Harness + Ignitor Assembly	2620823	2620824
16	Inner Skin	2620825	2620826
17	Wall Bracket Assembly	2620760-1	2620760-1
18	White Rodger Spacer	2620732	2620732
19	Control Mount	2620734	2620734
20	Honeywell Control	2120770	2120770
21	Honeywell Gas Valve	2120771	2120771
22	Brahma Control	2620829	2620829
23	White Rodger 24V Gas Valve	2620830	2620830
24	19mm ID Grommet	2620831	2620831
25	Gas Inlet Fitting (Honeywell 1/2" Gas Valve)	2620780	2620780
26	Gas Outlet Fittings ( Honeywell 1/2" Gas Valve)	2620781	2620781
27	Gas Inlet Fitting (WhiteRodgers Gas Valve)	2620782	2620782
28	Gas Outlet Fitting (WhiteRodgers Gas Valve)	2620783	2620783
29	Manifold Assembly	2620791	2620790
30	Injector (LPG)	4440080	4440080
30	Injector (NG)	4440130	4440130
31	Wall Bracket Replacement Screw Set	2620829	2620829
32	Heater Replacement Screw Set	2620840	2620840
33	Gas Hose		

## POST-INSTALLATION REPORT FOR PLATINUM GAS RADIANT HEATERS

AFTER HEATER INSTALLATION PLEASE PHOTOCOPY, COMPLETE, & SEND THIS REPORT BY:  
FAX TO (02) 9748 4289 or BY MAIL TO Bromic Heating Pty Ltd, 10 Phiney Place, Inglegurn NSW 2565 Australia  
or SCAN AND EMAIL TO info@bromicheating.com

Customer Business Name:

Date: dd / mm / yyyy

Site Address:



Suburb:

State: Postcode:

Customer Contact Details:

Name:

Position:

Ph: ( ) Fax: ( )

Mobile:

Installer Contact Details:

Name:

Position:

Ph: ( ) Fax: ( )

Mobile:

Please fill in the relevant information or circle the appropriate Yes/No responses below:

How many Platinum heaters are installed on this site?	3-Tile: _____	5-Tile: _____
What type of gas is used?	LPG	Natural Gas
Is/Are the heater(s) exposed to salt air or any other corrosive or chemical atmosphere?	Yes	No
Does the heater(s)' installation location pose a hazard to the site?	Yes	No
Do heater clearances match the minimum requirements outlined in the "Installation Requirements" section of the <i>Installation, Operation and Service Manual</i> ?	Yes	No
Is the gas supply line adequately sized for the number of heaters installed?	Yes	No
Have gas lines been purged of air?	Yes	No
Have gas lines been checked for leaks with a soapy water solution?	Yes	No
Was the heater field tested and operated without malfunction?	Yes	No
What is the <b>inlet</b> gas supply pressure?	_____ kPa	
What is the gas valve <b>outlet</b> pressure (at test point)?	_____ kPa	

Signature of authorised person:

Name:

Company: Position:

Date: dd / mm / yyyy

# TROUBLESHOOTING

SYMPTOM	POSSIBLE CAUSE	CORRECTIVE ACTION
Heater will not turn on	<ol style="list-style-type: none"> <li>1. No power</li> <li>2. No gas</li> </ol>	<ol style="list-style-type: none"> <li>1. Have authorised electrician check power supply</li> <li>2. Have authorised gas fitter check gas supply</li> </ol>
Heater turns on, but then cycles on and off	<ol style="list-style-type: none"> <li>1. Insufficient flame on ionisation rod</li> <li>2. Drafty conditions</li> <li>3. Insufficient earth connection between heater and control box</li> </ol>	<ol style="list-style-type: none"> <li>1. <ul style="list-style-type: none"> <li>• Check and set gas pressure</li> <li>• Check and clear obstruction to burner venturi and injectors</li> </ul> </li> <li>2. Discontinue use in high winds</li> <li>3. Replace wiring harness and clean connections to ensure good earth</li> </ol>
No gas	<ol style="list-style-type: none"> <li>1. Air in gas line</li> <li>2. Manual shut-off valve closed</li> <li>3. Regulator sticking</li> <li>4. Regulator reversed</li> </ol>	<ol style="list-style-type: none"> <li>1. Purge line</li> <li>2. Open valve</li> <li>3. Replace regulator</li> <li>4. Remove and install properly</li> </ol>
Low ceramic tile surface temperature	<ol style="list-style-type: none"> <li>1. Low manifold gas pressure</li> <li>2. Low gas inlet pressure</li> <li>3. Orifice partially blocked with foreign matter</li> <li>4. Combustion by-products not adequately ventilated</li> <li>5. Manifold misaligned from excessive torque applied on pipe at installation</li> <li>6. Gas supply piping too small</li> <li>7. Foreign matter in venturi tube</li> </ol>	<ol style="list-style-type: none"> <li>1. Adjust valve regulator until 1kpa for natural gas, or 2.75kpa for propane is obtained</li> <li>2. Adjust main supply regulator until at least 1.25kpa for natural gas or 3kpa for propane precedes heater's control assembly</li> <li>3. Clean orifice</li> <li>4. Provide adequate ventilation of by-products</li> <li>5. Replace manifold</li> <li>6. Increase gas pressure or replace piping</li> <li>7. Remove with bottle brush</li> </ol>
Gas odour	<ol style="list-style-type: none"> <li>1. Loose pipe connection</li> <li>2. Defective regulator</li> <li>3. Defective manual shut-off valve</li> <li>4. Defective gas control valve</li> <li>5. Loose flexible hose</li> </ol>	<ol style="list-style-type: none"> <li>1. Check all connections with soap solution and tighten where necessary</li> <li>2. Replace regulator</li> <li>3. Replace manual shut-off valve</li> <li>4. Replace gas control valve</li> <li>5. Tighten flexible hose</li> </ol>
Burning of gas/air mixture inside burner casting (flashback)	<ol style="list-style-type: none"> <li>1. Separation of ceramic tiles</li> <li>2. Ceramic tile(s) cracked</li> <li>3. Heater mounted at incorrect angle</li> <li>4. Excessive drafts</li> </ol>	<ol style="list-style-type: none"> <li>1. Replace burner assembly</li> <li>2. Replace burner assembly</li> <li>3. Check angle of heater. See heater nameplate.</li> <li>4. Shield or relocate heater.</li> </ol>
Control assembly is overheating	<ol style="list-style-type: none"> <li>1. Heater not mounted correctly</li> </ol>	<ol style="list-style-type: none"> <li>1. Mount wall bracket / control housing against a vertical flat surface, following the instructions outlined in the installation section of this manual. Always use supplied parts to mount heater.</li> </ol>
Carbon formation on ceramic tile surface of burner	<ol style="list-style-type: none"> <li>1. Misaligned orifice</li> <li>2. Obstruction in venturi tube</li> <li>3. Low gas pressure</li> <li>4. Wrong gas supplied to heater</li> </ol>	<ol style="list-style-type: none"> <li>1. Consult sales agent or factory</li> <li>2. Clean with bottle brush</li> <li>3. Provide required pressure</li> <li>4. Check label for type of gas required</li> </ol>



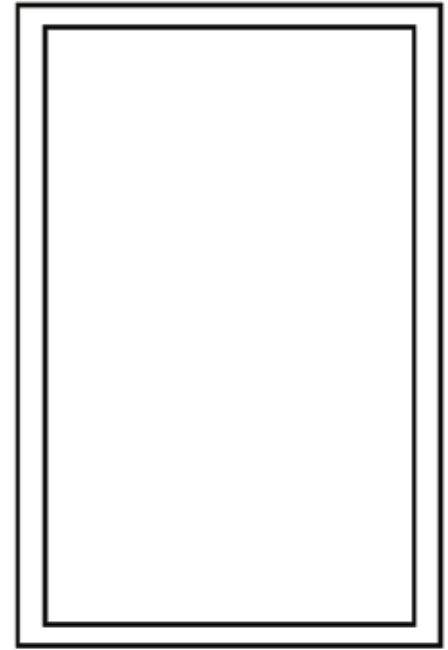
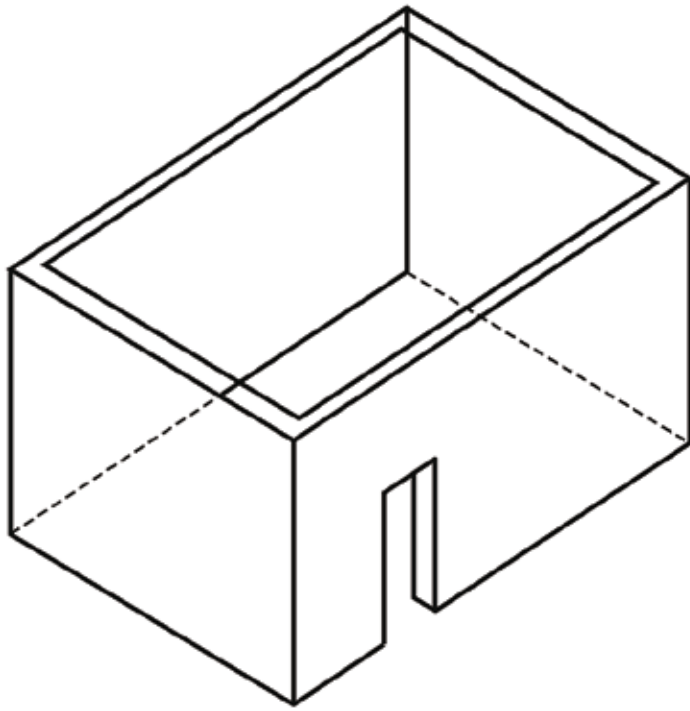

OUTDOOR AREA-EXAMPLE 1

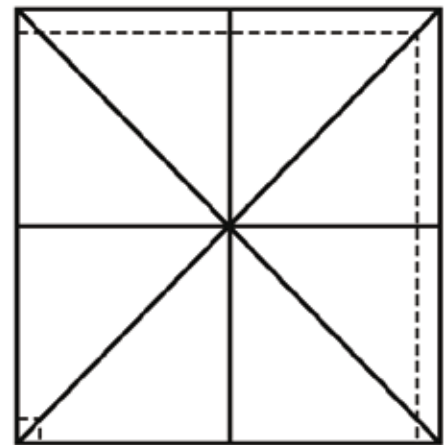
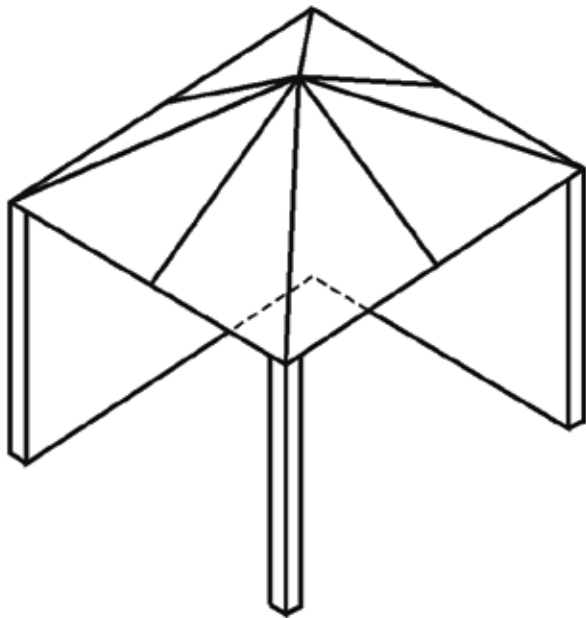

OUTDOOR AREA-EXAMPLE 2

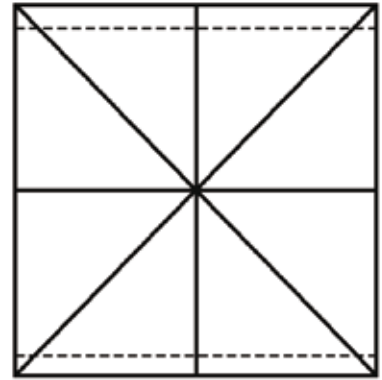
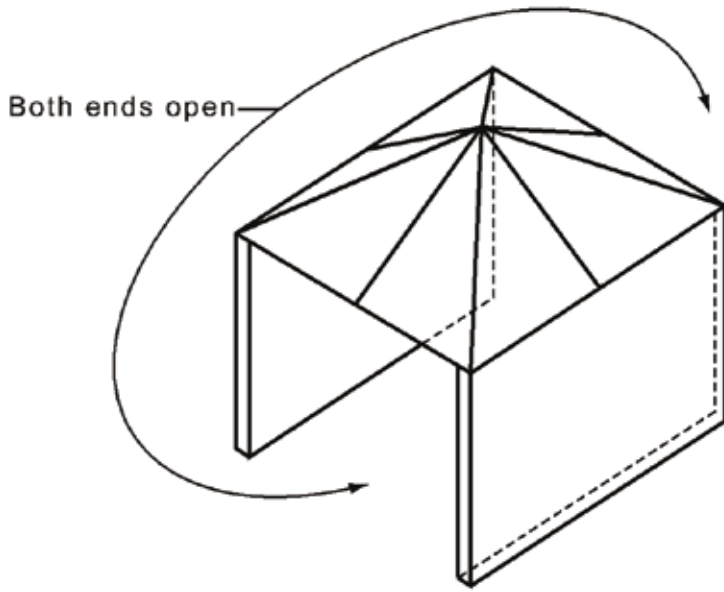

OUTDOOR AREA-EXAMPLE 3

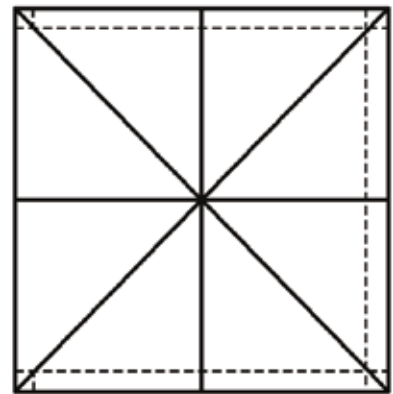
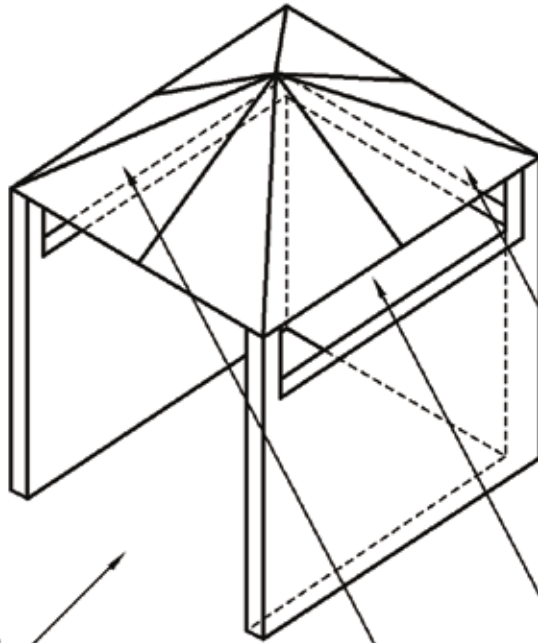

Open side at least 25% of total wall area

30 percent or more in total of the remaining wall area is open and unrestricted

OUTDOOR AREA-EXAMPLE 4

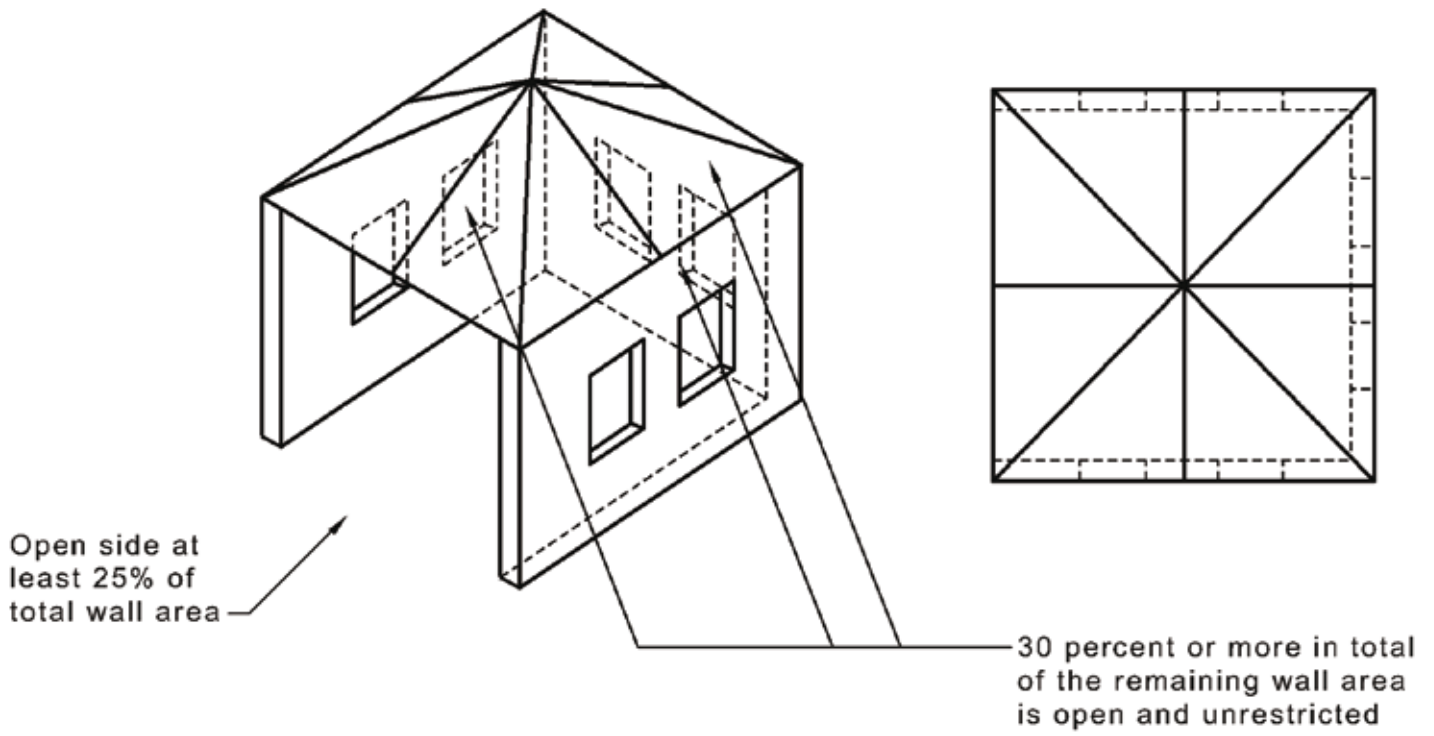

OUTDOOR AREA-EXAMPLE 5